



Member of



**INSTITUTO DE CIENCIAS  
DE LA CONSTRUCCIÓN  
EDUARDO TORROJA**

C/ Serrano Galvache, 4. 28033 Madrid (Spain)  
Tel.: (+34) 91 302 0440 [www.ietcc.csic.es](http://www.ietcc.csic.es)  
[gestiondit@ietcc.csic.es](mailto:gestiondit@ietcc.csic.es)  
[dit.ietcc.csic.es](http://dit.ietcc.csic.es)

## European Technical Assessment

**ETA 20/0046**  
**28/04/2025**

English translation prepared by IETcc. Original version in Spanish language

### General Part

#### Technical Assessment Body issuing the European Technical Assessment:

Instituto de Ciencias de la Construcción Eduardo Torroja (IETcc)

**Trade name of the construction product**

**Screw anchor THE**

**Product family to which the construction product belongs**

Screw anchor of sizes 6, 8, 10, 12, 14, 16 and 18 for use in concrete.

**Manufacturer**

**Index - Técnicas Expansivas S.L.**

Segador 13  
26006 Logroño (La Rioja) Spain.  
website: [www.indexfix.com](http://www.indexfix.com)

**Manufacturing plant**

Index plant 2

**This European Technical Assessment contains**

35 pages including 3 annexes which form an integral part of this assessment.

**This European Technical Assessment is issued in accordance with Regulation (EU) No 305/2011, on the basis of**

European Assessment Document EAD 330232-01-0601 "Mechanical Fasteners for use in concrete", ed. December 2019

**This ETA replaces**

ETA 20/0046 revision 5 dated 17/06/2024



Translations of this European Technical Assessment in other languages shall fully correspond to the original issued document.

Communication of this European Technical Assessment, including transmission by electronic means, shall be in full. However, partial reproduction may be made, with the written consent of the issuing Technical Assessment Body. Any partial reproduction has to be identified as such



## SPECIFIC PART

### 1. Technical description of the product

The Index screw anchor THE is a fastener made of carbon steel of sizes 6, 8, 10, 12, 14, 16 and 18. The Index screw anchor TXE is a fastener made of stainless steel of sizes 6, 8, 10 and 12. The fastener is installed into a predrilled cylindrical hole. The special thread of the fastener cuts an internal thread into the concrete member while setting. The anchorage is characterised by mechanical interlock between fastener and concrete.

Product and installation descriptions are given in annexes A1 and A2.

### 2. Specification of the intended use in accordance with the applicable European Assessment Document.

#### 2.1 Intended use

This ETA covers fasteners to be used in compacted, reinforced or unreinforced, normal weight, cracked or uncracked concrete without fibers with strength classes in the range of C20/25 to C50/60 all in accordance with EN 206, for static or quasi-static or under seismic actions (categories C1 and C2) and with requirements related to fire exposure, loaded in tension, shear or combined tension and shear.

The performances given in section 3 are only valid if the anchor is used in compliance with the specifications and conditions given in annexes B1 and B2.

#### 2.2 Relevant general conditions for the use of the product

The assessment methods included or referred to in this EAD have been written based on the manufacturer's request to take into account a working life of the fastener for the intended use of 50 years when installed in the works (provided that the fastener is subject to appropriate installation). These provisions are based upon the current state of the art and the available knowledge and experience.

When assessing the product, the intended use as foreseen by the manufacturer shall be taken into account. The real working life may be, in normal use conditions, considerably longer without major degradation affecting the basic requirements for works.

The indications given as to the working life of the construction product cannot be interpreted as a guarantee neither given by the product manufacturer or its representative nor by EOTA when drafting the EAD nor by the Technical Assessment Body issuing an ETA based on this EAD, but are regarded only as a mean for expressing the expected economically reasonable working life of the product.

This ETA covers fasteners for installation in pre-drilled holes in compacted reinforced or unreinforced normal weight concrete without fibers considering annexes B and C.

### 3. Performance of the product and references to the methods used for its assessment

The identification tests and the assessment for the intended use of this product according to the Basic Work Requirements (BWR) were carried out in compliance with EAD 330232-01-0601. The characteristics of each system shall correspond to the respective values laid down in following tables of this ETA, checked by IETcc.

Methods of verification and of assessing and judging are listed afterwards.



### 3.1 Mechanical resistance and stability (BWR 1)

Essential characteristic	Relevant clause in EAD	Performance	Annex
Resistance to steel failure	2.2.1	$N_{Rk,s}$ [kN]	C4, C5
Resistance to pull-out failure	2.2.2	$N_{Rk,p}$ [kN] $\psi_c$ [-]	C4, C5
Resistance to concrete cone failure	2.2.3	$k_{cr,N}$ , $k_{ucr,N}$ [-] $h_{ef}$ , $c_{cr,N}$ [mm]	C4, C5
Robustness	2.2.4	$\gamma_{inst}$ [-]	C4, C5
Minimum edge distance and spacing	2.2.5	$c_{min}$ , $s_{min}$ , $h_{min}$ [mm]	C1, C2
Edge distance to prevent splitting under load	2.2.6	$N^0_{Rk,sp}$ [kN], $c_{cr,sp}$ [mm]	C4, C5
Resistance to steel failure under shear load	2.2.7	$V^0_{Rk,s}$ [kN], $M^0_{Rk,s}$ [Nm], $k_7$ [-]	C6, C7
Resistance to pry-out failure	2.2.8	$k_8$ [-]	C6, C7
Displacement under static and quasi-static loading	2.2.10	$\delta_{N0}$ , $\delta_{N\infty}$ , $\delta_{V0}$ , $\delta_{V\infty}$ [mm]	C8, C9
Resistance to seismic tension loads; displacements	2.2.11 2.2.12	$N_{Rk,s,C1}$ , $N_{Rk,p,C1}$ [kN] $N_{Rk,s,C2}$ , $N_{Rk,p,C2}$ [kN], $\delta_{N,C2}$ [mm]	C10 to C12
Resistance to seismic shear loads; displacements	2.2.13 2.2.14	$V_{Rk,s,C1}$ [kN], $V_{Rk,s,C2}$ [kN], $\delta_{V,C2}$ [mm]	C10 to C12
Factor for annular gap	2.2.15	$\alpha_{gap}$ [-]	C10 to C12

### 3.2 Safety in case of fire (BWR 2)

Essential characteristic	Relevant clause in EAD	Performance	Annex
Reaction to fire	2.2.16	Anchorage satisfy requirements for class A1 according to EN 13501-1	--
Fire resistance to steel failure, tension load	2.2.17	$N^0_{Rk,s,fi}$ [kN]	C13 to C26
Fire resistance to pull out failure, tension load	2.2.18	$N^0_{Rk,p,fi}$ [kN]	C13 to C26
Fire resistance to steel failure, shear load	2.2.19	$V^0_{Rk,s,fi}$ [kN] $M^0_{Rk,s,fi}$ [Nm]	C13 to C26



### 3.3 Durability

Essential characteristic	Relevant clause in EAD	Performance	Annex
Durability:	2.2.20	Coated in zinc plated Coated in zinc nickel Coated in zinc flake Coated mechanical galvanized Coated in Atlantis Stainless steel	A2

#### 4. Assessment and Verification of Constancy of Performance (hereinafter AVCP) system applied, with reference to its legal base

The applicable European legal act for the system of Assessment and Verification of Constancy of Performance (see annex V to Regulation (EU) No 305/2011) is 96/582/EC.

The system to be applied is 1.

#### 5. Technical details necessary for the implementation of the AVCP system, as provided for in the applicable European Assessment Document.

Technical details necessary for the implementation of the AVCP system are laid down in the quality plan which is deposited at IETcc<sup>(1)</sup>.

Prepared by: PhD Julián Rivera (Innovative Products Assessment Unit, IETcc-CSIC)

Issued in Madrid on 28<sup>th</sup> of April 2025





Mr. Ángel Castillo Talavera

Director

on behalf of Instituto de Ciencias de la Construcción Eduardo Torroja (IETcc – CSIC)

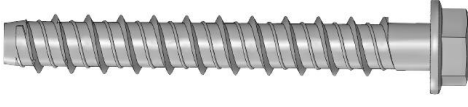
<sup>(1)</sup> The Quality Plan is a confidential part of the ETA and only handed over to the notified certification body involved in the assessment and verification of constancy of performance.

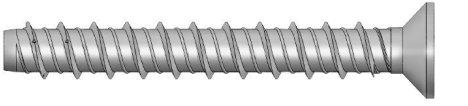
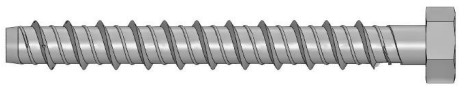
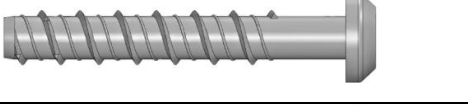
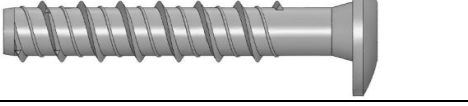
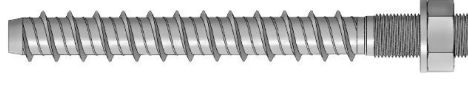
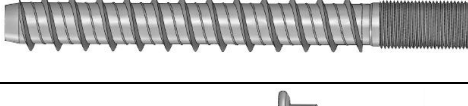
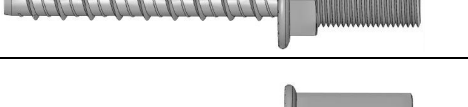

<b>Product types</b>			
<b>Picture</b>	<b>Material / coating</b>	<b>Head styles / Sizes</b>	
	Carbon steel:  -H: Atlantis  -F: Zinc plated  -N: Zinc flake  -K: Zinc nickel  -G: Mechanical galvanized	-E, -K: Hexagonal head with flange. Sizes: 6, 8, 10, 12, 14, 16 and 18	
		-J: Hexagonal head with flange. Six lobe recess. Size: 6	
		-A: Countersunk head, Six lobe recess Sizes: 6, 8 10 and 12	
		-N: Hexagonal head. Sizes: 6, 8, 10, 12, 14, 16 and 18	
		-P: Pan head. Six lobe recess Sizes: 6 and 8	
		-T: Truss head. Six lobe recess. Size: 6	
		Stainless steel:  -X: A4 stainless steel	-W: Stud head with DIN 934 class 6 nut and DIN 125 washer Sizes: 6 M8, 8 M10, 10 M12, 12 M14, 14 M16, 16 M18 and 18 M20
			-S: Stud head Sizes: 6 M8, 8 M10, 10 M12, 12 M14, 14 M16, 16 M18 and 18 M20
			-M: Male thread Size: 6, external thread M8, M10; 8 external thread M10, M12
			-F: Rod hanger Size 6: internal thread M10; combi thread M8/M10 Size 8: internal thread M10; M12
<b>THE, TXE screw anchor</b>		<b>Annex A1</b>	
<b>Product description</b>			
Screw types			



**Installed condition**

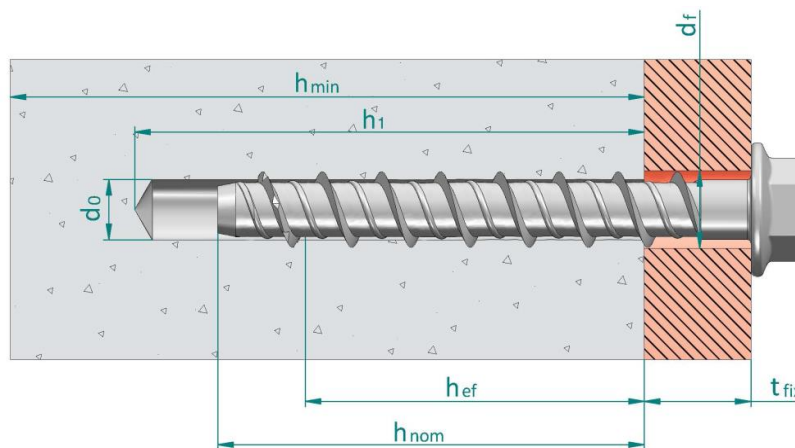

- d<sub>0</sub>: Nominal diameter of drill bit
- d<sub>f</sub>: Fixture clearance hole diameter
- h<sub>ef</sub>: Effective anchorage depth
- h<sub>1</sub>: Depth of drilled hole
- h<sub>nom</sub>: Overall fastener embedment depth in the concrete
- h<sub>min</sub>: Minimum thickness of concrete member
- t<sub>fix</sub>: Fixture thickness

Identification on head of fastener: company logo + size x length

The tip of the thread may be coloured.

For heads where no enough space is available, the length of the mark can be replaced by the following letter codes.

Letter on head	Length [mm]
A	35 ÷ 50
B	51 ÷ 62
C	63 ÷ 75
D	76 ÷ 88
E	89 ÷ 101
F	102 ÷ 113
G	114 ÷ 126
H	127 ÷ 139
I	140 ÷ 153

**Table A1: Materials**

Item	Designation	Material for screw anchor THE	Material for screw anchor TXE
1	Fastener body	Carbon steel, galvanized ≥ 5 µm ISO 4042 Zn5 Carbon steel, zinc nickel ≥ 8 µm ISO 4042, ZnNi8/An/T2 Carbon steel, zinc flake ≥ 6 µm ISO 10683 Carbon steel, mechanical galvanizing ≥ 40 µm EN ISO 12683 Zn 40 M(Fe) Carbon steel, Atlantis coating	Shaft and head: stainless steel grade A4 ISO 3506-1 Tip: hardened carbon steel

**THE, TXE screw anchor**

**Product description**

Installed condition and materials

**Annex A2**



<b>Specifications of intended use</b>																
<b>Size</b>	<b>6</b>			<b>8</b>		<b>10</b>			<b>12</b>		<b>14</b>		<b>16</b>		<b>18</b>	
$h_{nom}$	35	40	55	50	65	55	75	85	75	105	75	115	80	120	90	140
<b>THE</b>																
Static or quasi static loads	✓	✓	✓	✓	✓	✓	✓	✓	✓	✓	✓	✓	✓	✓	✓	✓
Seismic category C1		✓	✓	✓	✓			✓		✓		✓				✓
Seismic category C2				✓	✓			✓		✓		✓				✓
Fire exposure up to 120 minutes	✓	✓	✓	✓	✓	✓	✓	✓	✓	✓	✓	✓	✓	✓	✓	✓
<b>TXE</b>																
Static or quasi static loads	✓	✓	✓	✓	✓	✓		✓	✓	✓						
Seismic category C1		✓	✓	✓	✓	✓		✓	✓	✓						
Seismic category C2																
Fire exposure up to 120 minutes	✓	✓	✓	✓	✓	✓		✓	✓	✓						
<b>Base materials:</b>																
<ul style="list-style-type: none"> <li>Reinforced or unreinforced normal weight concrete without fibres according to EN 206:2013 + A2:2021.</li> <li>Strength classes C20/25 to C50/60 according to EN 206:2013 + A2:2021.</li> <li>Cracked or uncracked concrete.</li> </ul>																
<b>Use conditions:</b>																
<ul style="list-style-type: none"> <li>THE: environmental conditions: anchorages subjected to dry internal conditions.</li> <li>TXE: environmental conditions: anchorages subjected to dry internal conditions, to external atmospheric exposure (including industrial and marine environment) or to permanent internal damp conditions if no particular aggressive conditions exist. Such particular aggressive conditions are e.g., permanent, alternating immersion in seawater or the splash zone of seawater, chloride atmosphere of indoor swimming pools or atmosphere with extreme chemical pollution (e.g., in desulphurization plants or road tunnels where de-icing materials are used). Atmospheres under Corrosion Resistance Class CRC III according to EN 1993-1-4:2006+A1:2015 annex A.</li> <li>Male and female version: the metric thread shall be equal or bigger than the net section of the concrete thread</li> </ul>																
<b>THE, TXE screw anchor</b>															<b>Annex B1</b>	
<b>Intended use</b>																
<b>Specifications</b>																



<p><b>Design:</b></p> <ul style="list-style-type: none"> <li>• Anchorages are designed under the responsibility of an engineer experienced in anchorages and concrete work.</li> <li>• Verifiable calculation rules and drawings are prepared taking into account of the loads to be anchored. The position of the fastener is indicated on the design drawings (e.g., position of the fastener relative to reinforcement or to supports, etc.).</li> <li>• Anchorages under static or quasi static actions are designed for design method A in accordance with EN 1992-4:2018.</li> <li>• Anchorages under seismic actions are designed in accordance with EN 1992-4:2018. Anchorages shall be positioned outside of critical regions (e.g., plastic hinges) of the concrete structure. Fastening in stand-off installation or with grout layer are not allowed.</li> <li>• Anchorages under fire exposure are designed in accordance with EN 1992-4:2018. It must be ensured that local spalling of the concrete cover does not occur.</li> </ul> <p><b>Installation:</b></p> <ul style="list-style-type: none"> <li>• Hole drilling by rotary plus hammer mode: all sizes and embedment depths.</li> <li>• Fastener installation carried out by appropriately qualified personal and under the supervision of the person responsible for technical matters of the site.</li> <li>• In case of aborted hole: new drilling at a minimum distance away of twice the depth of aborted hole or smaller distance if the aborted hole is filled with high strength mortar and if under shear or oblique tension load it is not the direction of the load application.</li> <li>• After installation further turning of the anchor must not be possible.</li> <li>• The head of the fastener must be supported on the fixture and is not damaged.</li> </ul>	
<b>THE, TXE screw anchor</b>	<b>Annex B2</b>
<b>Intended use</b>	
Specifications	



**Table C1: Installation parameters THE**

Installation parameters THE			Performances							
			6		8		10			
$h_{nom}$	Nominal embedment depth:	[mm]	35	40	55	50	65	55	75	85
$h_{ef}$	Effective anchorage depth:	[mm]	26,0	30,0	43,0	37,5	50,5	41,5	58,5	67,0
$d_o$	Nominal diameter of drill bit:	[mm]	6		8		10			
$d_f$	Clearance hole diameter $\leq$	[mm]	7,5 $\div$ 9		10,5 $\div$ 12		12,5 $\div$ 14			
$T_{inst,max}$	Installation torque $\leq$	[Nm]	10		20		30			
$h_1$	Depth of drilled hole $\geq$	[mm]	45	50	65	60	75	65	85	95
$h_{min}$	Minimum thickness of concrete member:	[mm]	100	100	100	100	100	100	120	135
$L_{min}$	Minimum total length of the fastener:	[mm]	35	40	55	50	65	55	75	85
$t_{fix}$	Thickness of fixture <sup>1)</sup> :	[mm]	L-35	L-40	L-55	L-50	L-65	L-55	L-75	L-85
SW	Socket size	Hexagonal type E,N	[mm]	10		13		15		
		Hexagonal type K:	[mm]	10		13		17		
		Hexagonal type J:	[mm]	13		--		--		
		Male:	[mm]	13		17		--		
		Rod hanger:	[mm]	13		13 / 17 <sup>2)</sup>		--		
	Stud:	[mm]	5		7		8			
TX	Six lobe recess	Countersunk:	[-]	30		45		50		
		Pan:	[-]	40		45		--		
		Truss:	[-]	30		--		--		
$d_k$	Diam. of countersunk head:	[mm]	12,4		18		21			
$s_{min}$	Minimum allowable spacing:	[mm]	35		35		50			
$c_{min}$	Minimum allowable distance:	[mm]	35		35		40			
Setting tool:			Bosch GDS 18E, 500 W. $T_{impact,max}$ 250 Nm, or equivalent			Makita TW0350, 400 W, $T_{impact,max}$ 350 Nm, or equivalent		Bosch GDS 24, 800 W. $T_{impact,max}$ 600 Nm, or equivalent		

<sup>1)</sup> L = total fastener length  
<sup>2)</sup> Socket 13 for M10; socket 17 for M12

Installation parameters THE			Performances								
			12		14		16		18		
$h_{nom}$	Nominal embedment depth:	[mm]	75	105	75	115	80	120	90	140	
$h_{ef}$	Effective anchorage depth:	[mm]	58,0	83,5	58,0	92,0	58,0	92,0	69,5	112,0	
$d_o$	Nominal diameter of drill bit:	[mm]	12		14		16		18		
$d_f$	Clearance hole diameter $\leq$	[mm]	14,8 $\div$ 16		16,9 $\div$ 18		18,9 $\div$ 20		20,9 $\div$ 22		
$T_{inst,max}$	Installation torque $\leq$	[Nm]	50		70		80		90		
$h_1$	Depth of drilled hole $\geq$	[mm]	90	120	90	130	100	140	110	160	
$h_{min}$	Minimum thickness of concrete member:	[mm]	120	170	120	185	115	185	140	225	
$L_{min}$	Minimum total length of the fastener:	[mm]	75	105	75	115	80	120	90	140	
$t_{fix}$	Thickness of fixture <sup>1)</sup> :	[mm]	L-75	L-105	L-75	L-115	L-80	L-120	L-90	L-140	
SW	Socket size:	Hexagonal type E,N	[mm]	18		21		24		24	
		Hexagonal type K:	[mm]	19		21		24		26	
		Rod hanger:	[mm]	M12: 19		--		--		--	
		Stud:	[mm]	10		11		13		14	
TX	Six lobe recess countersunk	[-]	55		--		--		--		
$d_k$	Diam. of countersunk head:	[mm]	24		--		--		--		
$s_{min}$	Minimum allowable spacing:	[mm]	75		80		80		90		
$c_{min}$	Minimum allowable edge distance:	[mm]	45		50		50		55		
Setting tool:			Bosch GDS 24, 800 W. $T_{impact,max}$ 600 Nm, or equivalent								

<sup>1)</sup> L = total fastener length

**THE screw anchor**

**Performances**



Installation parameters

**Annex C1**



<b>Table C2: Installation parameters TXE</b>												
Installation parameters TXE				Performances								
				6			8		10		12	
$h_{nom}$	Nominal embedment depth:	[mm]	35	40	55	50	65	55	85	75	105	
$h_{ef}$	Effective anchorage depth:	[mm]	26,0	30,0	43,0	37,5	50,5	41,5	67,0	58,0	83,5	
$d_o$	Nominal diameter of drill bit:	[mm]	6			8		10		12		
$d_f$	Clearance hole diameter $\leq$	[mm]	9			12		14		16		
$T_{inst,max}$	Installation torque $\leq$	[Nm]	10			20		30		50		
$h_1$	Depth of drilled hole $\geq$	[mm]	45	50	65	60	75	65	95	90	120	
$h_{min}$	Minimum thickness of concrete member:	[mm]	80	80	80	80	80	80	100	120	160	
$L_{min}$	Minimum total length of the fastener:	[mm]	35	40	55	50	65	55	85	75	105	
$t_{fix}$	Thickness of fixture <sup>1)</sup> :	[mm]	L-35	L-40	L-55	L-50	L-65	L-55	L-85	L-75	L-105	
SW	Socket size	Hexagonal type: E,N:	10			13		15		18		
		Hexagonal type: K:	10			13		17		19		
		Hexagonal type: J:	13			--		--		--		
		Male:	13			17		--		--		
		Rod hanger:	13			13 / 17 <sup>2)</sup>		--		--		
TX	Six lobe recess	Stud:	5			7		8		10		
		Countersunk:	30			45		50		55		
		Pan:	40			45		--		--		
$d_k$	Diameter of countersunk head:	Truss:	30			--		--		--		
			12,4			18		21		24		
			35			35		50		75		
$S_{min}$	Minimum allowable spacing:	[mm]	35			35		50		75		
$C_{min}$	Minimum allowable distance:	[mm]	35			35		40		45		
Setting tool				Bosch GDS 18E, 500 W. $T_{impact,max}$ 250 Nm, or equivalent				Bosch GDS 24, 800 W. $T_{impact,max}$ 600 Nm, or equivalent				
<sup>1)</sup> L = total fastener length <sup>2)</sup> Socket 13 for M10; socket 17 for M12												
<b>TXE screw anchor</b>										<b>Annex C2</b>		
<b>Performances</b>												
Installation parameters												

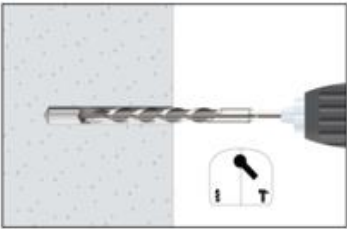

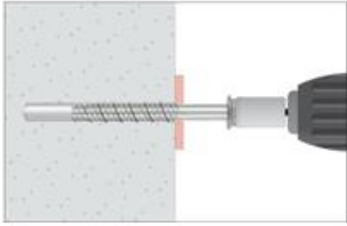
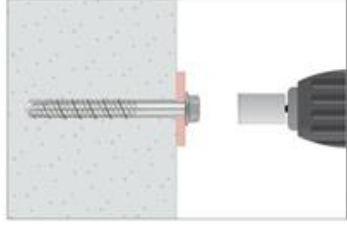
<b>Installation procedure</b>	
	<p><b>1. DRILL</b></p> <p>Drill a hole into the base material of the correct diameter and depth using a carbide drill bit in rotary plus hammer mode.</p>
	<p><b>2. BLOW AND CLEAN</b></p> <p>Remove dust and debris from hole using a hand pump, compressed air or a vacuum to remove loose particles left from drilling.</p>
	<p><b>3. INSTALL</b></p> <p>Select a powered impact wrench or a torque wrench that does not exceed the maximum torque <math>T_{impact,max}</math> or <math>T_{inst,max}</math> respectively. Attach an appropriately sized hex socket or six lob bit to the wrench. Mount the screw anchor head in the socket / bit.</p>
	<p><b>4. APPLY TORQUE</b></p> <p>Drive the anchor with an impact driver or a torque wrench through the fixture and into the hole until the anchor head comes in contact with the fixture. The anchor must be snug after installation. Do not spin the socket off the anchor to disengage.</p>
<p><b>THE, TXE screw anchor</b></p>	
<p><b>Performances</b></p>	<p><b>Annex C3</b></p>
<p>Installation procedure</p>	



**Table C3: Essential characteristics under static or quasi-static tension loads of design method A according to EN1992-4, THE anchor**

Essential characteristics under static or quasi-static tension loads according to design method A, THE anchor			Performances								
			6			8			10		
$h_{nom}$	Nominal embedment depth:	[mm]	35	40	55	50	65	55	75	85	
<b>Resistance to steel failure</b>											
$N_{Rk,s}$	Characteristic resistance:	[kN]	25,12			39,14		54,81			
$\gamma_{Ms}$	Partial safety factor <sup>1)</sup> :	[-]	1,4								
<b>Resistance to pull out failure</b>											
$N_{Rk,p}$	Characteristic resistance in C20/25 uncracked concrete:	[kN]	5	$\geq N_{Rk,c}^{0,2)}$							
$N_{Rk,p}$	Characteristic resistance in C20/25 cracked concrete:	[kN]	$\geq N_{Rk,c}^{0,2)}$								
$\psi_c$	Increasing factor for concrete	C30/37	[-]	1,16	1,12	1,22	1,21	1,22	1,22	1,17	1,22
		C40/50	[-]	1,28	1,22	1,41	1,39	1,41	1,41	1,30	1,41
		C50/60	[-]	1,39	1,29	1,58	1,54	1,58	1,58	1,42	1,58
<b>Resistance to concrete cone and splitting failure</b>											
$h_{ef}$	Effective anchorage depth:	[mm]	26,0	30,0	43,0	37,5	50,5	41,5	58,5	67,0	
$k_{ucr,N}$	Factor for uncracked concrete:	[-]	11,0								
$k_{cr,N}$	Factor for cracked concrete:	[-]	7,7								
$\gamma_{inst}$	Robustness:	[-]	1,2	1,2	1,0	1,2	1,0	1,0	1,0	1,0	
$s_{cr,N}$	Concrete Spacing:	[mm]	3 x $h_{ef}$								
$c_{cr,N}$	cone failure Edge distance:	[mm]	1,5 x $h_{ef}$								
$N_{Rk,sp}^0$	Charact. splitting resistance:	[kN]	$\min(N_{Rk,p}; N_{Rk,c}^0)$								
$s_{cr,sp}$	Spitting Spacing:	[mm]	90	90	170	130	200	140	190	210	
$c_{cr,sp}$	failure Edge distance:	[mm]	45	45	85	65	100	70	95	105	

<sup>1)</sup> In absence of other national regulations; <sup>2)</sup> Pull out failure is not decisive.  $N_{Rk,c}^0$  calculated according to EN 1992-4

Essential characteristics under static or quasi-static tension loads according to design method A, THE anchor			Performances								
			12		14		16		18		
$h_{nom}$	Nominal embedment depth:	[mm]	75	105	75	115	80	120	90	140	
<b>Resistance to steel failure</b>											
$N_{Rk,s}$	Characteristic resistance:	[kN]	74,48		105,45		124,41		161,56		
$\gamma_{Ms}$	Partial safety factor <sup>1)</sup> :	[-]	1,4								
<b>Resistance to pull out failure</b>											
$N_{Rk,p}$	Characteristic resistance in C20/25 uncracked concrete:	[kN]	$\geq N_{Rk,c}^{0,2)}$								
$N_{Rk,p}$	Characteristic resistance in C20/25 cracked concrete:	[kN]	$\geq N_{Rk,c}^{0,2)}$								
$\psi_c$	Increasing factor for concrete	C30/37	[-]	1,16	1,22	1,21	1,20	1,12	1,16	1,22	1,17
		C40/50	[-]	1,29	1,41	1,39	1,37	1,21	1,28	1,40	1,32
		C50/60	[-]	1,40	1,58	1,55	1,51	1,29	1,39	1,57	1,42
<b>Resistance to concrete cone and splitting failure</b>											
$h_{ef}$	Effective anchorage depth:	[mm]	58,0	83,5	58,0	92,0	58,0	92,0	69,5	112,0	
$k_{ucr,N}$	Factor for uncracked concrete:	[-]	11,0								
$k_{cr,N}$	Factor for cracked concrete:	[-]	7,7								
$\gamma_{inst}$	Robustness:	[-]	1,0								
$s_{cr,N}$	Concrete Spacing:	[mm]	3 x $h_{ef}$								
$c_{cr,N}$	cone failure Edge distance:	[mm]	1,5 x $h_{ef}$								
$N_{Rk,sp}^0$	Charact. splitting resistance:	[kN]	$\min(N_{Rk,p}; N_{Rk,c}^0)$								
$s_{cr,sp}$	Spitting Spacing:	[mm]	190	220	190	230	180	280	230	350	
$c_{cr,sp}$	failure Edge distance:	[mm]	95	110	95	115	90	140	115	175	

<sup>1)</sup> In absence of other national regulations; <sup>2)</sup> Pull out failure is not decisive.  $N_{Rk,c}^0$  calculated according to EN 1992-4

<b>THE screw anchor</b>	<b>Annex C4</b>
<b>Performances</b>	
Essential characteristics under static or quasi-static tension loads	



<b>Table C4: Essential characteristics under static or quasi-static tension loads of design method A according to EN1992-4, TXE anchor</b>												
Essential characteristics under static or quasi-static tension loads according to design method A, TXE anchor			Performances									
			6			8		10		12		
$h_{nom}$	Nominal embedment depth:	[mm]	35	40	55	50	65	55	85	75	105	
<b>Resistance to steel failure</b>												
$N_{Rk,s}$	Characteristic resistance:	[kN]	17,58			29,30		48,13		69,67		
$\gamma_{Ms}$	Partial safety factor <sup>1)</sup> :	[-]	1,5									
<b>Resistance to pull out failure</b>												
$N_{Rk,p}$	Characteristic resistance in C20/25 uncracked concrete:	[kN]	5,5	$\geq N_{Rk,c}^{(2)}$	12,0	10,0	$\geq N_{Rk,c}^{(2)}$	$\geq N_{Rk,c}^{(2)}$	$\geq N_{Rk,c}^{(2)}$	$\geq N_{Rk,c}^{(2)}$	$\geq N_{Rk,c}^{(2)}$	
$N_{Rk,p}$	Characteristic resistance in C20/25 cracked concrete:	[kN]	1,0	2,5	7,5	5,0	$\geq N_{Rk,c}^{(2)}$	$\geq N_{Rk,c}^{(2)}$	$\geq N_{Rk,c}^{(2)}$	14,0	$\geq N_{Rk,c}^{(2)}$	
$\Psi_c$	Increasing factor for concrete	C30/37	1,12	1,10	1,06	1,10	1,08	1,08	1,08	1,10	1,08	
		C40/50	1,21	1,18	1,10	1,17	1,15	1,14	1,14	1,18	1,15	
		C50/60	1,29	1,24	1,14	1,23	1,19	1,19	1,18	1,25	1,19	
<b>Resistance to concrete cone and splitting failure</b>												
$h_{ef}$	Effective anchorage depth:	[mm]	26,0	30,0	43,0	37,5	50,5	41,5	67,0	58,0	83,5	
$k_{ucr,N}$	Factor for uncracked concrete:	[-]	11,0									
$k_{cr,N}$	Factor for cracked concrete:	[-]	7,7									
$\gamma_{inst}$	Robustness:	[-]	1,2	1,2	1,2	1,2	1,2	1,2	1,2	1,2	1,0	
$s_{cr,N}$	Concrete cone failure	Spacing:	[mm]	3 x $h_{ef}$								
$c_{cr,N}$	Edge distance	[mm]	1,5 x $h_{ef}$									
$N_{Rk,sp}^0$	Characteristic splitting resistance:	[kN]	min ( $N_{Rk,p}$ ; $N_{Rk,c}^0$ )									
$s_{cr,sp}$	Spitting failure	Spacing:	[mm]	90	110	190	130	220	140	230	190	240
$c_{cr,sp}$	Edge distance	[mm]	45	55	95	65	110	70	115	95	120	
<sup>1)</sup> In absence of other national regulations <sup>2)</sup> Pull out failure is not decisive. $N_{Rk,c}^0$ calculated according to EN 1992-4												
<b>TXE screw anchor</b>										<b>Annex C5</b>		
<b>Performances</b>												
Essential characteristics under static or quasi-static tension loads												



**Table C5: Essential characteristics under static or quasi-static shear loads of design method A according to EN 1992-4, THE anchor**

Essential characteristics under static or quasi-static shear loads according to design method A, THE anchor		Performances							
		6			8		10		
$h_{nom}$	Nominal embedment depth: [mm]	35	40	55	50	65	55	75	85
<b>Resistance to steel failure under shear loads</b>									
$V_{Rk,s}^0$	Characteristic resistance: [kN]	12,53			19,57		27,40		
$k_7$	Ductility factor <sup>2)</sup> : [-]	0,78	0,80	0,78	0,80		0,80		
$M_{Rk,s}^0$	Characteristic bending moment: [Nm]	21,6			44,6		78,3		
$\gamma_{Ms}$	Partial safety factor <sup>1)</sup> : [-]	1,5							
<b>Resistance to pry-out failure</b>									
$k_8$	Pry-out factor: [-]	2,05	1,44	1,15	1,80	1,27	1,95	1,32	2,00
$\gamma_{inst}$	Robustness: [-]	1,0							
<b>Resistance to concrete edge failure</b>									
$l_f$	Effective length of fastener under shear loads: [mm]	26,0	30,0	43,0	37,5	50,5	41,5	58,5	67,0
$d_{nom}$	Outside fastener diameter: [mm]	6			8		10		
$\gamma_{inst}$	Robustness: [-]	1,0							

1) In absence of other national regulations

2) The diameter of the clearance hole does not meet the values given in EN 1992-4 Table 6.1. However, the group resistance under shear loading has been verified in the assessment through testing and accounted for in the factor  $k_7$

Essential characteristics under static or quasi-static shear loads according to design method A, THE anchor		Performances							
		12		14		16		18	
$h_{nom}$	Nominal embedment depth: [mm]	75	105	75	115	80	120	90	140
<b>Resistance to steel failure under shear loads</b>									
$V_{Rk,s}^0$	Characteristic resistance: [kN]	37,24		52,72		57,97		80,78	
$k_7$	Ductility factor <sup>2)</sup> : [-]	1,00							
$M_{Rk,s}^0$	Characteristic bending moment: [Nm]	126,5		218,3		279,75		421,2	
$\gamma_{Ms}$	Partial safety factor <sup>1)</sup> : [-]	1,5							
<b>Resistance to pry-out failure</b>									
$k_8$	Pry-out factor: [-]	2,33	2,00	2,55	2,00	2,14	2,00	2,66	2,00
$\gamma_{inst}$	Robustness: [-]	1,0							
<b>Resistance to concrete edge failure</b>									
$l_f$	Effective length of fastener under shear loads: [mm]	58,0	83,5	58,0	92,0	58,0	92,0	69,5	112,0
$d_{nom}$	Outside fastener diameter: [mm]	12		14		16		18	
$\gamma_{inst}$	Robustness: [-]	1,0							

1) In absence of other national regulations

2) The diameter of the clearance hole does not meet the values given in EN 1992-4 Table 6.1. However, the group resistance under shear loading has been verified in the assessment through testing and accounted for in the factor  $k_7$

**THE screw anchor**

**Performances**

Essential characteristics under static or quasi-static shear loads

**Annex C6**



**Table C6: Essential characteristics under static or quasi-static shear loads of design method A according to EN 1992-4, TXE anchor**

Essential characteristics under static or quasi-static shear loads according to design method A, TXE anchor		Performances									
		6			8		10		12		
$h_{nom}$	Nominal embedment depth: [mm]	35	40	55	50	65	55	85	75	105	
<b>Resistance to steel failure under shear loads</b>											
$V_{Rk,s}^0$	Characteristic resistance: [kN]	8,79			14,65		24,06		34,84		
$k_7$	Ductility factor <sup>2)</sup> : [-]	1,00									
$M_{Rk,s}^0$	Characteristic bending moment: [Nm]	14,52			31,17		65,68		146,01		
$\gamma_{Ms}$	Partial safety factor <sup>1)</sup> : [-]	1,25									
<b>Resistance to pry-out failure</b>											
$k_8$	Pry-out factor: [mm]	1,87	1,66	1,05	1,71	1,39	1,83	2,00	2,19	2,00	
$\gamma_{inst}$	Robustness: [-]	1,0									
<b>Resistance to concrete edge failure</b>											
$l_f$	Effective length of fastener under shear loads: [mm]	26,0	30,0	43,0	37,5	50,5	41,5	67,0	58,0	83,5	
$d_{nom}$	Outside fastener diameter: [mm]	6			8		10		12		
$\gamma_{inst}$	Robustness: [-]	1,0									

<sup>1)</sup> In absence of other national regulations

<sup>2)</sup> The diameter of the clearance hole does not meet the values given in EN 1992-4 Table 6.1. However, the group resistance under shear loading has been verified in the assessment through testing and accounted for in the factor  $k_7$

<b>TXE screw anchor</b>	<b>Annex C7</b>
<b>Performances</b>	
Essential characteristics under static or quasi-static shear loads	



**Table C7: Displacements under service loads THE anchor**

Displacements under service loads THE anchor		Performances								
		6			8			10		
$h_{nom}$	Nominal embedment depth: [mm]	35	40	55	50	65	55	75	85	
<b>Displacements under tension loads in uncracked concrete</b>										
N	Service tension load: [kN]	1,98	3,85	6,61	4,48	8,41	6,26	10,48	12,85	
$\delta_{N0}$	Short term displacement: [mm]	0,03	0,05	0,05	0,04	0,05	0,06	0,09	0,10	
$\delta_{N\infty}$	Long term displacement: [mm]	0,25	0,30	0,30	0,26	0,35	0,30	0,42	0,65	
<b>Displacements under tension loads in cracked concrete</b>										
N	Service tension load: [kN]	1,81	2,69	4,62	3,14	5,88	4,38	7,34	8,99	
$\delta_{N0}$	Short term displacement: [mm]	0,08	0,09	0,10	0,09	0,20	0,11	0,35	0,44	
$\delta_{N\infty}$	Long term displacement: [mm]	0,99	0,99	1,60	1,08	1,92	1,13	2,00	1,91	
<b>Displacements under shear loads in uncracked concrete</b>										
V	Service shear load: [kN]	5,97	5,54	5,97	9,32	9,32	12,21	13,05	13,05	
$\delta_{V0}$	Short term displacement: [mm]	1,50	1,61	1,70	1,03	1,03	1,11	1,21	1,24	
$\delta_{V\infty}$	Long term displacement: [mm]	2,25	2,41	2,55	1,54	1,54	1,66	1,81	1,86	
<b>Displacements under shear loads in cracked concrete</b>										
V	Service shear load: [kN]	4,46	3,88	5,32	6,78	7,47	8,55	9,68	13,05	
$\delta_{V0}$	Short term displacement: [mm]	0,95	0,96	1,45	0,66	0,70	0,74	1,03	1,09	
$\delta_{V\infty}$	Long term displacement: [mm]	1,42	1,44	2,17	0,99	1,05	1,11	1,54	1,63	

Displacements under service loads THE anchor		Performances							
		12		14		16		18	
$h_{nom}$	Nominal embedment depth: [mm]	75	105	75	115	80	120	90	140
<b>Displacements under tension loads in uncracked concrete</b>									
N	Service tension load: [kN]	10,35	17,87	10,35	20,67	10,35	20,67	13,57	27,77
$\delta_{N0}$	Short term displacement: [mm]	0,10	0,11	0,12	0,15	0,12	0,20	0,17	0,23
$\delta_{N\infty}$	Long term displacement: [mm]	0,40	0,68	0,46	0,70	0,60	0,74	0,50	0,71
<b>Displacements under tension loads in cracked concrete</b>									
N	Service tension load: [kN]	7,24	12,51	7,24	14,47	7,24	14,47	9,50	19,44
$\delta_{N0}$	Short term displacement: [mm]	0,24	0,46	0,34	0,51	0,39	0,59	0,41	0,55
$\delta_{N\infty}$	Long term displacement: [mm]	1,32	1,78	1,40	1,80	1,41	1,85	1,56	2,08
<b>Displacements under shear loads in uncracked concrete</b>									
V	Service shear load: [kN]	17,73	17,73	25,10	25,10	22,14	33,12	36,10	38,47
$\delta_{V0}$	Short term displacement: [mm]	1,65	1,65	1,87	1,87	1,04	1,61	1,96	2,03
$\delta_{V\infty}$	Long term displacement: [mm]	2,48	2,48	2,81	2,81	1,56	2,42	2,94	3,05
<b>Displacements under shear loads in cracked concrete</b>									
V	Service shear load: [kN]	16,88	17,73	18,47	25,10	15,50	28,94	25,27	38,47
$\delta_{V0}$	Short term displacement: [mm]	1,30	1,34	1,40	1,70	0,86	1,56	1,34	1,80
$\delta_{V\infty}$	Long term displacement: [mm]	1,95	2,01	2,10	2,55	1,29	2,34	2,01	2,70

<b>THE screw anchor</b>	<b>Annex C8</b>
<b>Performances</b>	
Displacements under static or quasi-static tension and shear loads	



<b>Table C8: Displacements under service loads TXE anchor</b>											
Displacements under service loads TXE anchor			Performances								
			6			8		10		12	
$h_{nom}$	Nominal embedment depth:	[mm]	35	40	55	50	65	55	85	75	105
<b>Displacements under tension loads in uncracked concrete</b>											
N	Service tension load:	[kN]	2,34	3,21	4,93	4,25	7,00	5,22	10,71	8,62	17,88
$\delta_{N0}$	Short term displacement:	[mm]	0,04	0,04	0,06	0,09	0,10	0,10	0,12	0,12	0,18
$\delta_{N\infty}$	Long term displacement:	[mm]	0,28	0,30	0,30	0,35	0,40	0,40	0,45	0,45	0,50
<b>Displacements under tension loads in cracked concrete</b>											
N	Service tension load:	[kN]	0,56	1,07	3,20	2,06	4,90	3,65	7,50	5,63	12,51
$\delta_{N0}$	Short term displacement:	[mm]	0,06	0,07	0,14	0,13	0,15	0,17	0,18	0,20	0,23
$\delta_{N\infty}$	Long term displacement:	[mm]	0,60	0,53	0,86	0,55	1,11	0,57	0,92	0,67	1,06
<b>Displacements under shear loads in uncracked concrete</b>											
V	Service shear load:	[kN]	4,36	5,06	5,06	7,70	8,37	9,50	13,75	18,90	19,91
$\delta_{V0}$	Short term displacement:	[mm]	1,70	1,85	1,85	1,89	1,90	2,14	2,26	2,38	2,35
$\delta_{V\infty}$	Long term displacement:	[mm]	2,60	2,78	2,78	2,84	2,85	3,21	3,39	3,57	3,53
<b>Displacements under shear loads in cracked concrete</b>											
V	Service shear load:	[kN]	3,40	3,80	4,00	5,40	6,80	6,70	13,75	13,20	19,91
$\delta_{V0}$	Short term displacement:	[mm]	1,72	1,80	1,81	1,84	1,87	1,95	2,25	2,16	2,35
$\delta_{V\infty}$	Long term displacement:	[mm]	2,58	2,70	2,72	2,76	2,81	2,93	3,38	3,24	3,53
<b>TXE screw anchor</b>										<b>Annex C9</b>	
<b>Performances</b>											
Displacements under static or quasi-static tension and shear loads											



**Table C9: Essential characteristics for seismic performance category C1, THE anchor**

Essential characteristics for seismic performance category C1, THE anchor			Performances							
			6		8		10	12	14	18
$h_{nom}$	Nominal embedment depth:	[mm]	40	55	50	65	85	105	115	140
<b>Resistance to steel failure under tension loads</b>										
$N_{Rk,s,C1}$	Characteristic resistance:	[kN]	25,12	25,12	39,14	39,14	54,81	74,48	105,45	161,56
$\gamma_{Ms}$	Partial safety factor <sup>1)</sup> :	[-]	1,4							
<b>Resistance to steel failure under shear loads</b>										
$V_{Rk,s,C1}$	Characteristic resistance:	[kN]	5,9	9,4	8,7	11,7	19,2	23,5	31,7	44,1
$\gamma_{Ms}$	Partial safety factor <sup>1)</sup> :	[-]	1,5							
$\alpha_{gap}$	Factor for annular gap:	[-]	0,5							
<b>Resistance to pull-out failure</b>										
$N_{Rk,p,C1}$	Characteristic resistance in cracked concrete:	[kN]	5,0	5,0	6,2	8,8	14,7	18,2	23,2	35,3
$\gamma_{inst}$	Robustness:	[-]	1,2	1,0	1,2	1,0	1,0	1,0	1,0	1,0
<b>Resistance to concrete cone failure</b>										
$h_{ef}$	Effective depth:	[mm]	30,0	43,0	37,5	50,5	67,0	83,5	92,0	112,0
$s_{cr,N}$	Spacing:	[mm]	3 x $h_{ef}$							
$c_{cr,N}$	Edge distance:	[mm]	1,5 x $h_{ef}$							
$\gamma_{inst}$	Robustness:	[-]	1,2	1,0	1,2	1,0	1,0	1,0	1,0	1,0
<b>Resistance to pry-out failure</b>										
$k_8$	Pry-out factor:	[-]	1,44	1,15	1,80	1,27	2,00	2,00	2,00	2,00
$\gamma_{inst}$	Robustness:	[-]	1,0							
<b>Resistance to concrete edge failure</b>										
$l_f$	Effective length of fastener under shear loads:	[mm]	30,0	43,0	37,5	50,5	67,0	83,5	92,0	112,0
$d_{nom}$	Outside fastener diameter:	[mm]	6	6	8	8	10	12	14	18
$\gamma_{inst}$	Robustness:	[-]	1,0							

<sup>1)</sup> In absence of other national regulations

<b>THE screw anchor</b>	<b>Annex C10</b>
<b>Performances</b>	
Essential characteristics for seismic performance category C1	



**Table C10: Essential characteristics for seismic performance category C1, TXE anchor**

Essential characteristics for seismic performance category C1, TXE anchor			Performances							
			6		8		10		12	
$h_{nom}$	Nominal embedment depth:	[mm]	40	55	50	65	55	85	75	105
<b>Resistance to steel failure under tension loads</b>										
$N_{Rk,s,C1}$	Characteristic resistance:	[kN]	17,58		29,30		48,13		69,67	
$\gamma_{Ms}$	Partial safety factor <sup>1)</sup> :	[-]	1,5							
<b>Resistance to steel failure under shear loads</b>										
$V_{Rk,s,C1}$	Characteristic resistance:	[kN]	5,83	8,44	8,04	10,00	15,16	19,86	25,96	30,80
$\gamma_{Ms}$	Partial safety factor <sup>1)</sup> :	[-]	1,25							
$\alpha_{gap}$	Factor for annular gap:	[-]	0,5							
<b>Resistance to pull-out failure</b>										
$N_{Rk,p,C1}$	Characteristic resistance in cracked concrete:	[kN]	2,12	5,70	3,64	8,77	6,69	12,84	9,87	21,53
$\gamma_{inst}$	Robustness:	[-]	1,2	1,2	1,2	1,2	1,2	1,2	1,2	1,0
<b>Resistance to concrete cone failure</b>										
$h_{ef}$	Effective depth:	[mm]	30,0	43,0	37,5	50,5	41,5	67,0	58,0	83,5
$S_{cr,N}$	Spacing:	[mm]	3 x $h_{ef}$							
$C_{cr,N}$	Edge distance:	[mm]	1,5 x $h_{ef}$							
$\gamma_{inst}$	Robustness:	[-]	1,2	1,2	1,2	1,2	1,2	1,2	1,2	1,0
<b>Resistance to pry-out failure</b>										
$k_8$	Pry-out factor:	[-]	1,66	1,05	1,71	1,39	1,83	2,00	2,19	2,00
$\gamma_{inst}$	Robustness:	[-]	1,0							
<b>Resistance to concrete edge failure</b>										
$l_f$	Effective length of fastener under shear loads:	[mm]	30,0	43,0	37,5	50,5	41,5	67,0	58,0	83,5
$d_{nom}$	Outside fastener diameter:	[mm]	6		8		10		12	
$\gamma_{inst}$	Robustness:	[-]	1,0							

<sup>1)</sup> In absence of other national regulations

<b>TXE screw anchor</b>	<b>Annex C11</b>
<b>Performances</b>	
Essential characteristics for seismic performance category C1	



**Table C11: Essential characteristics for seismic performance category C2, THE anchor**

Essential characteristics for seismic performance category C2, THE anchor			Performances						
			6	8		10	12	14	18
$h_{nom}$	Nominal embedment depth:	[mm]	--	50	65	85	105	115	140
<b>Resistance to steel failure under tension loads</b>									
$N_{Rk,s,C2}$	Characteristic resistance:	[kN]	--	39,14	39,14	54,81	74,48	105,45	161,56
$\gamma_{Ms}$	Partial safety factor <sup>1)</sup> :	[-]	1,4						
<b>Resistance to steel failure under shear loads</b>									
$V_{Rk,s,C2}$	Characteristic resistance:	[kN]	--	8,4	11,7	19,2	23,5	31,7	44,1
$\gamma_{Ms}$	Partial safety factor <sup>1)</sup> :	[-]	1,5						
$\alpha_{gap}$	Factor for annular gap:	[-]	0,5						
<b>Resistance to pull-out failure</b>									
$N_{Rk,p,C2}$	Characteristic resistance in cracked concrete:	[kN]	--	2,3	3,4	6,9	10,5	15,3	31,5
$\gamma_{inst}$	Robustness:	[-]	--	1,2	1,0	1,0	1,0	1,0	1,0
<b>Resistance to concrete cone failure</b>									
$h_{ef}$	Effective depth:	[mm]	--	37,5	50,5	67,0	83,5	92,0	112,0
$S_{cr,N}$	Spacing:	[mm]	--	3 x $h_{ef}$					
$C_{cr,N}$	Edge distance:	[mm]	--	1,5 x $h_{ef}$					
$\gamma_{inst}$	Robustness:	[-]	--	1,0					
<b>Resistance to pry-out failure</b>									
$k_8$	Pry-out factor:	[-]	--	1,80	1,27	2,00	2,00	2,00	2,00
$\gamma_{inst}$	Robustness:	[-]	--	1,0					
<b>Resistance to concrete edge failure</b>									
$l_f$	Effective length of fastener under shear loads:	[mm]	--	37,5	50,5	67,0	83,5	92,0	112,0
$d_{nom}$	Outside fastener diameter:	[mm]	--	8	8	10	12	14	18
$\gamma_{inst}$	Robustness:	[-]	--	1,0					
<b>Displacements</b>									
$\delta_{N,C2} (DLS)$	Displacement Damage Limitation State: <sup>2)</sup>	[mm]	--	0,36	0,16	0,22	0,41	0,25	0,66
$\delta_{V,C2} (DLS)$	Displacement Damage Limitation State: <sup>2)</sup>	[mm]	--	1,60	0,79	1,13	1,69	1,52	1,69
$\delta_{N,C2} (ULS)$	Displacement Ultimate Limit State: <sup>2)</sup>	[mm]	--	1,08	2,70	3,11	2,61	2,32	1,89
$\delta_{V,C2} (ULS)$	Displacement Ultimate Limit State: <sup>2)</sup>	[mm]	--	2,54	4,74	7,43	9,03	6,29	8,79
DLS	Damage Limitation State: see EN 1992-4, 2.2.1)								
ULS	Ultimate Limitation State: see EN 1992-4 2.2.1)								

<sup>1)</sup> In absence of other national regulations

<sup>2)</sup> The listed displacements represent mean values

**THE screw anchor**

**Performances**

Essential characteristics for seismic performance category C2

**Annex C12**



**Table C12: Essential characteristics under fire exposure, carbon steel head styles E, K and J**

Essential characteristics under fire exposure, carbon steel head styles E, K and J				Performances							
				6			8		10		
$h_{nom}$	Nominal embedment depth:	[mm]		35	40	55	50	65	55	75	85
<b>Fire resistance to steel failure</b>											
$N_{Rk,s,fi}$	Characteristic tension resistance:	R30	[kN]	1,48			2,62		4,21		
		R60	[kN]	1,12			1,97		3,16		
		R90	[kN]	0,76			1,33		2,10		
		R120	[kN]	0,58			1,00		1,58		
$V_{Rk,s,fi}$	Characteristic shear resistance:	R30	[kN]	1,48			2,62		4,21		
		R60	[kN]	1,12			1,97		3,16		
		R90	[kN]	0,76			1,33		2,10		
		R120	[kN]	0,58			1,00		1,58		
$M^0_{Rk,s,fi}$	Characteristic bending resistance:	R30	[Nm]	1,27			2,94		5,90		
		R60	[Nm]	0,97			2,22		4,42		
		R90	[Nm]	0,66			1,49		2,94		
		R120	[Nm]	0,50			1,13		2,21		
<b>Fire resistance to pull-out failure</b>											
$N_{Rk,c,fi}$	Characteristic resistance:	R30 - R90	[kN]	1,14	1,41	2,43	1,98	3,09	2,30	3,85	4,72
		R120	[kN]	0,91	1,13	1,94	1,58	2,47	1,84	3,08	3,78
<b>Fire resistance to concrete cone failure <sup>1)</sup></b>											
$N_{Rk,c,fi}$	Characteristic resistance:	R30 - R90	[kN]	0,59	0,85	2,09	1,48	3,12	1,91	4,51	6,33
		R120	[kN]	0,47	0,68	1,67	1,19	2,50	1,53	3,61	5,06
$Scr_{N,fi}$	Spacing:	R30 - R120	[mm]	4 x $h_{ef}$							
$S_{min,fi}$	Minimum spacing:	R30 - R120	[mm]	35		35		50			
$C_{cr,N,fi}$	Edge distance:	R30 - R120	[mm]	2 x $h_{ef}$							
$C_{min,fi}$	Minimum edge distance:	R30 - R120	[mm]	$C_{min} = 2 \times h_{ef}$ ; if fire attack comes from more than one side, the edge distance of the anchor has to be $\geq 300$ mm							
<b>Fire resistance to concrete pry-out failure</b>											
$k_8$	Pry-out factor:	R30 - R120	[mm]	2,05	1,44	1,15	1,80	1,27	1,95	1,32	2,00

<sup>1)</sup> As a rule, splitting failure can be neglected since cracked concrete and reinforcement is assumed.

In absence of other national regulations the partial safety factor for resistance under fire exposure  $\gamma_{m,fi} = 1,0$  is recommended

<b>THE screw anchor</b>	<b>Annex C13</b>
<b>Performances</b>	
Essential characteristics under fire exposure	



**Table C13: Essential characteristics under fire exposure, carbon steel head styles E, K and J (cont)**

Essential characteristics under fire exposure, carbon steel head styles E, K and J				Performances							
				12		14		16		18	
$h_{nom}$	Nominal embedment depth:	[mm]		75	105	75	115	80	120	90	140
<b>Fire resistance to steel failure</b>											
$N_{Rk,s,fi}$	Characteristic tension resistance:	R30	[kN]	7,61		9,10		12,04		14,88	
		R60	[kN]	5,24		6,80		8,99		11,11	
		R90	[kN]	3,46		4,49		5,93		7,33	
		R120	[kN]	2,57		3,33		4,41		5,45	
$V_{Rk,s,fi}$	Characteristic shear resistance:	R30	[kN]	7,61		9,10		12,04		14,88	
		R60	[kN]	5,24		6,80		8,99		11,11	
		R90	[kN]	3,46		4,49		5,93		7,33	
		R120	[kN]	2,57		3,33		4,41		5,45	
$M^0_{Rk,s,fi}$	Characteristic bending resistance:	R30	[Nm]	11,96		18,12		27,56		38,52	
		R60	[Nm]	8,93		13,53		20,57		28,75	
		R90	[Nm]	5,90		8,93		13,59		18,99	
		R120	[Nm]	4,38		6,63		10,09		14,10	
<b>Fire resistance to pull-out failure</b>											
$N_{Rk,p,fi}$	Characteristic resistance:	R30 - R90	[kN]	3,80	6,57	3,80	7,60	3,80	7,60	4,99	10,20
		R120	[kN]	3,04	5,25	3,04	6,08	3,04	6,08	3,99	8,16
<b>Fire resistance to concrete cone failure <sup>1)</sup></b>											
$N_{Rk,c,fi}$	Characteristic resistance:	R30 - R90	[kN]	4,41	10,97	4,41	13,98	4,41	13,98	6,93	22,86
		R120	[kN]	3,53	8,78	3,53	11,18	3,53	11,18	5,55	18,29
$S_{cr,N,fi}$	Spacing:	R30 - R120	[mm]	4 x $h_{ef}$							
$S_{min,fi}$	Minimum spacing:	R30 - R120	[mm]	75		80		80		90	
$C_{cr,N,fi}$	Edge distance:	R30 - R120	[mm]	2 x $h_{ef}$							
$C_{min,fi}$	Minimum edge distance:	R30 - R120	[mm]	$C_{min} = 2 \times h_{ef}$ ; if fire attack comes from more than one side, the edge distance of the anchor has to be $\geq 300$ mm							
<b>Fire resistance to concrete pry-out failure</b>											
$k_8$	Pry-out factor:	R30 - R120	[mm]	2,33	2,00	2,55	2,00	2,14	2,00	2,66	2,00

<sup>1)</sup> As a rule, splitting failure can be neglected since cracked concrete and reinforcement is assumed.

In absence of other national regulations the partial safety factor for resistance under fire exposure  $\gamma_{m,fi} = 1,0$  is recommended

<b>THE screw anchor</b>	<b>Annex C14</b>
<b>Performances</b>	
Essential characteristics under fire exposure	



**Table C14: Essential characteristics under fire exposure, carbon steel head styles N, A, W and S**

Essential characteristics under fire exposure, carbon steel head styles N, A, W and S				Performances							
				6			8		10		
$h_{nom}$	Nominal embedment depth:	[mm]		35	40	55	50	65	55	75	85
<b>Fire resistance to steel failure</b>											
$N_{Rk,s,fi}$	Characteristic tension resistance:	R30	[kN]	0,26			0,45		1,07		
		R60	[kN]	0,23			0,41		0,93		
		R90	[kN]	0,18			0,32		0,71		
		R120	[kN]	0,13			0,23		0,57		
$V_{Rk,s,fi}$	Characteristic shear resistance:	R30	[kN]	0,26			0,45		1,07		
		R60	[kN]	0,23			0,41		0,93		
		R90	[kN]	0,18			0,32		0,71		
		R120	[kN]	0,13			0,23		0,57		
$M^0_{Rk,s,fi}$	Characteristic bending resistance:	R30	[Nm]	0,22			0,52		1,52		
		R60	[Nm]	0,20			0,46		1,32		
		R90	[Nm]	0,16			0,36		1,02		
		R120	[Nm]	0,11			0,26		0,81		
<b>Fire resistance to pull-out failure</b>											
$N_{Rk,c,fi}$	Characteristic resistance:	R30 - R90	[kN]	1,14	1,41	2,43	1,98	3,09	2,30	3,85	4,72
		R120	[kN]	0,91	1,13	1,94	1,58	2,47	1,84	3,08	3,78
<b>Fire resistance to concrete cone failure <sup>1)</sup></b>											
$N_{Rk,c,fi}$	Characteristic resistance:	R30 - R90	[kN]	0,59	0,85	2,09	1,48	3,12	1,91	4,51	6,33
		R120	[kN]	0,47	0,68	1,67	1,19	2,50	1,53	3,61	5,06
$s_{cr,N,fi}$	Spacing:	R30 - R120	[mm]	4 x $h_{ef}$							
$s_{min,fi}$	Minimum spacing:	R30 - R120	[mm]	35		35		50			
$c_{cr,N,fi}$	Edge distance:	R30 - R120	[mm]	2 x $h_{ef}$							
$c_{min,fi}$	Minimum edge distance:	R30 - R120	[mm]	$c_{min} = 2 \times h_{ef}$ ; if fire attack comes from more than one side, the edge distance of the anchor has to be $\geq 300$ mm							
<b>Fire resistance to concrete pry-out failure</b>											
$k_8$	Pry-out factor:	R30 - R120	[mm]	2,05	1,44	1,15	1,80	1,27	1,95	1,32	2,00

<sup>1)</sup> As a rule, splitting failure can be neglected since cracked concrete and reinforcement is assumed.

In absence of other national regulations the partial safety factor for resistance under fire exposure  $\gamma_{m,fi} = 1,0$  is recommended

<b>THE screw anchor</b>	<b>Annex C15</b>
<b>Performances</b>	
Essential characteristics under fire exposure	



**Table C15: Essential characteristics under fire exposure, carbon steel head styles N, A, W and S (cont)**

Essential characteristics under fire exposure, carbon steel head styles N, A, W and S			Performances							
			12		14		16		18	
$h_{nom}$	Nominal embedment depth:	[mm]	75	105	75	115	80	120	90	140
<b>Fire resistance to steel failure</b>										
$N_{Rk,s,fi}$	Characteristic tension resistance:	R30 [kN]	2,01		2,99		3,53		4,74	
		R60 [kN]	1,51		2,24		2,65		3,56	
		R90 [kN]	1,31		1,94		2,29		3,08	
		R120 [kN]	1,01		1,50		1,76		2,37	
$V_{Rk,s,fi}$	Characteristic shear resistance:	R30 [kN]	2,01		2,99		3,53		4,74	
		R60 [kN]	1,51		2,24		2,65		3,56	
		R90 [kN]	1,31		1,94		2,29		3,08	
		R120 [kN]	1,01		1,50		1,76		2,37	
$M^0_{Rk,s,fi}$	Characteristic bending resistance:	R30 [Nm]	3,42		6,19		7,94		12,37	
		R60 [Nm]	2,56		4,64		5,95		9,28	
		R90 [Nm]	2,22		4,02		5,16		8,04	
		R120 [Nm]	1,71		3,10		3,97		6,18	
<b>Fire resistance to pull-out failure</b>										
$N_{Rk,p,fi}$	Characteristic resistance:	R30 - R90 [kN]	3,80	6,57	3,80	7,60	3,80	7,60	4,99	10,20
		R120 [kN]	3,04	5,25	3,04	6,08	3,04	6,08	3,99	8,16
<b>Fire resistance to concrete cone failure <sup>1)</sup></b>										
$N_{Rk,c,fi}$	Characteristic resistance:	R30 - R90 [kN]	4,41	10,97	4,41	13,98	4,41	13,98	6,93	22,86
		R120 [kN]	3,53	8,78	3,53	11,18	3,53	11,18	5,55	18,29
$S_{cr,N,fi}$	Spacing:	R30 - R120 [mm]	4 x $h_{ef}$							
$S_{min,fi}$	Minimum spacing:	R30 - R120 [mm]	75		80		80		90	
$C_{cr,N,fi}$	Edge distance:	R30 - R120 [mm]	2 x $h_{ef}$							
$C_{min,fi}$	Minimum edge distance:	R30 - R120 [mm]	$C_{min} = 2 \times h_{ef}$ ; if fire attack comes from more than one side, the edge distance of the anchor has to be $\geq 300$ mm							
<b>Fire resistance to concrete pry-out failure</b>										
$k_8$	Pry-out factor:	R30 - R120 [mm]	2,33	2,00	2,55	2,00	2,14	2,00	2,66	2,00

<sup>1)</sup> As a rule, splitting failure can be neglected since cracked concrete and reinforcement is assumed.  
In absence of other national regulations the partial safety factor for resistance under fire exposure  $\gamma_{m,fi} = 1,0$  is recommended

<b>THE screw anchor</b>	<b>Annex C16</b>
<b>Performances</b>	
Essential characteristics under fire exposure	



**Table C16: Essential characteristics under fire exposure, carbon steel head style P**

Essential characteristics under fire exposure, carbon steel head style P			Performances				
			6			8	
$h_{nom}$	Nominal embedment depth:	[mm]	35	40	55	50	65
<b>Fire resistance to steel failure</b>							
$N_{Rk,s,fi}$	Characteristic tension resistance:	R30 [kN]	0,87			2,76	
		R60 [kN]	0,59			2,06	
		R90 [kN]	0,30			1,35	
		R120 [kN]	0,16			1,00	
$V_{Rk,s,fi}$	Characteristic shear resistance:	R30 [kN]	0,87			2,76	
		R60 [kN]	0,59			2,06	
		R90 [kN]	0,30			1,35	
		R120 [kN]	0,16			1,00	
$M^0_{Rk,s,fi}$	Characteristic bending resistance:	R30 [Nm]	0,75			3,11	
		R60 [Nm]	0,51			2,31	
		R90 [Nm]	0,26			1,52	
		R120 [Nm]	0,14			1,12	
<b>Fire resistance to pull-out failure</b>							
$N_{Rk,c,fi}$	Characteristic resistance:	R30 - R90 [kN]	1,14	1,41	2,43	1,98	3,09
		R120 [kN]	0,91	1,13	1,94	1,58	2,47
<b>Fire resistance to concrete cone failure <sup>1)</sup></b>							
$N_{Rk,c,fi}$	Characteristic resistance:	R30 - R90 [kN]	0,59	0,85	2,09	1,48	3,12
		R120 [kN]	0,47	0,68	1,67	1,19	2,50
$s_{cr,N,fi}$	Spacing:	R30 - R120 [mm]	4 x $h_{ef}$				
$s_{min,fi}$	Minimum spacing:	R30 - R120 [mm]	35		35		
$c_{cr,N,fi}$	Edge distance:	R30 - R120 [mm]	2 x $h_{ef}$				
$c_{min,fi}$	Minimum edge distance:	R30 - R120 [mm]	$c_{min} = 2 \times h_{ef}$ ; if fire attack comes from more than one side, the edge distance of the anchor has to be $\geq 300$ mm				
<b>Fire resistance to concrete pry-out failure</b>							
$k_8$	Pry-out factor:	R30 - R120 [mm]	2,05	1,44	1,15	1,80	1,27

<sup>2)</sup> As a rule, splitting failure can be neglected since cracked concrete and reinforcement is assumed.  
In absence of other national regulations the partial safety factor for resistance under fire exposure  $\gamma_{m,fi} = 1,0$  is recommended

<b>THE screw anchor</b>	<b>Annex C17</b>
<b>Performances</b>	
Essential characteristics under fire exposure	



**Table C17: Essential characteristics under fire exposure, carbon steel head style T**

Essential characteristics under fire exposure, carbon steel head style T			Performances		
			6		
$h_{nom}$	Nominal embedment depth:	[mm]	35	40	55
<b>Fire resistance to steel failure</b>					
$N_{Rk,s,fi}$	Characteristic tension resistance:	R30 [kN]	1,62		
		R60 [kN]	1,14		
		R90 [kN]	0,67		
		R120 [kN]	0,43		
$V_{Rk,s,fi}$	Characteristic shear resistance:	R30 [kN]	1,62		
		R60 [kN]	1,14		
		R90 [kN]	0,67		
		R120 [kN]	0,43		
$M^0_{Rk,s,fi}$	Characteristic bending resistance:	R30 [Nm]	1,40		
		R60 [Nm]	0,99		
		R90 [Nm]	0,58		
		R120 [Nm]	0,37		
<b>Fire resistance to pull-out failure</b>					
$N_{Rk,c,fi}$	Characteristic resistance:	R30 - R90 [kN]	1,14	1,41	2,43
		R120 [kN]	0,91	1,13	1,94
<b>Fire resistance to concrete cone failure <sup>1)</sup></b>					
$N_{Rk,c,fi}$	Characteristic resistance:	R30 - R90 [kN]	0,59	0,85	2,09
		R120 [kN]	0,47	0,68	1,67
$S_{cr,N,fi}$	Spacing:	R30 - R120 [mm]	4 x $h_{ef}$		
$S_{min,fi}$	Minimum spacing:	R30 - R120 [mm]	35		
$C_{cr,N,fi}$	Edge distance:	R30 - R120 [mm]	2 x $h_{ef}$		
$C_{min,fi}$	Minimum edge distance:	R30 - R120 [mm]	$C_{min} = 2 \times h_{ef}$ ; if fire attack comes from more than one side, the edge distance of the anchor has to be $\geq 300$ mm		
<b>Fire resistance to concrete pry-out failure</b>					
$k_8$	Pry-out factor:	R30 - R120 [mm]	2,05	1,44	1,15

<sup>1)</sup> As a rule, splitting failure can be neglected since cracked concrete and reinforcement is assumed.  
In absence of other national regulations the partial safety factor for resistance under fire exposure  $\gamma_{m,fi} = 1,0$  is recommended

<b>THE screw anchor</b>	<b>Annex C18</b>
<b>Performances</b>	
Essential characteristics under fire exposure	



**Table C18: Essential characteristics under fire exposure, carbon steel head style M**

Essential characteristics under fire exposure, carbon steel head style M			Performances				
			6			8	
$h_{nom}$	Nominal embedment depth:	[mm]	35	40	55	50	60
<b>Fire resistance to steel failure</b>							
$N_{Rk,s,fi}$	Characteristic tension resistance:	R30 [kN]	0,87			0,87	
		R60 [kN]	0,72			0,72	
		R90 [kN]	0,58			0,58	
		R120 [kN]	0,51			0,51	
$V_{Rk,s,fi}$	Characteristic shear resistance:	R30 [kN]	0,87			0,87	
		R60 [kN]	0,72			0,72	
		R90 [kN]	0,58			0,58	
		R120 [kN]	0,51			0,51	
$M^0_{Rk,s,fi}$	Characteristic bending resistance:	R30 [Nm]	0,75			0,75	
		R60 [Nm]	0,62			0,62	
		R90 [Nm]	0,50			0,50	
		R120 [Nm]	0,44			0,44	
<b>Fire resistance to pull-out failure</b>							
$N_{Rk,c,fi}$	Characteristic resistance:	R30 - R90 [kN]	1,14	1,41	2,43	1,98	3,09
		R120 [kN]	0,91	1,13	1,94	1,58	2,47
<b>Fire resistance to concrete cone failure <sup>1)</sup></b>							
$N_{Rk,c,fi}$	Characteristic resistance:	R30 - R90 [kN]	0,59	0,85	2,09	1,48	3,12
		R120 [kN]	0,47	0,68	1,67	1,19	2,50
$S_{cr,N,fi}$	Spacing:	R30 - R120 [mm]	4 x $h_{ef}$				
$S_{min,fi}$	Minimum spacing:	R30 - R120 [mm]	35			35	
$C_{cr,N,fi}$	Edge distance:	R30 - R120 [mm]	2 x $h_{ef}$				
$C_{min,fi}$	Minimum edge distance:	R30 - R120 [mm]	$C_{min} = 2 \times h_{ef}$ ; if fire attack comes from more than one side, the edge distance of the anchor has to be $\geq 300$ mm				
<b>Fire resistance to concrete pry-out failure</b>							
$k_8$	Pry-out factor:	R30 - R120 [mm]	2,05	1,44	1,15	1,80	1,27

<sup>1)</sup> As a rule, splitting failure can be neglected since cracked concrete and reinforcement is assumed.

In absence of other national regulations the partial safety factor for resistance under fire exposure  $\gamma_{m,fi} = 1,0$  is recommended

<b>THE screw anchor</b>	<b>Annex C19</b>
<b>Performances</b>	
Essential characteristics under fire exposure	



**Table C19: Essential characteristics under fire exposure, carbon steel head style F**

Essential characteristics under fire exposure, carbon steel head style F			Performances				
			6			8	
	Inner thread	[-]	M8/M10	M10	M8/M10	M10; M12	
$h_{nom}$	Nominal embedment depth:	[mm]	35	40	55	50	65
<b>Fire resistance to steel failure</b>							
$N_{Rk,s,fi}$	Characteristic tension resistance:	R30 [kN]	0,66	1,01	0,66	1,44	
		R60 [kN]	0,56	0,83	0,56	1,07	
		R90 [kN]	0,46	0,65	0,46	0,70	
		R120 [kN]	0,41	0,57	0,41	0,51	
$V_{Rk,s,fi}$	Characteristic shear resistance:	R30 [kN]	0,66	1,01	0,66	1,44	
		R60 [kN]	0,56	0,83	0,56	1,07	
		R90 [kN]	0,46	0,65	0,46	0,70	
		R120 [kN]	0,41	0,57	0,41	0,51	
$M^0_{Rk,s,fi}$	Characteristic bending resistance:	R30 [Nm]	0,57	0,87	0,57	1,62	
		R60 [Nm]	0,48	0,72	0,48	1,20	
		R90 [Nm]	0,40	0,56	0,40	0,78	
		R120 [Nm]	0,35	0,49	0,35	0,57	
<b>Fire resistance to pull-out failure</b>							
$N_{Rk,c,fi}$	Characteristic resistance:	R30 - R90 [kN]	1,14	1,41	2,43	1,98	3,09
		R120 [kN]	0,91	1,13	1,94	1,58	2,47
<b>Fire resistance to concrete cone failure <sup>1)</sup></b>							
$N_{Rk,c,fi}$	Characteristic resistance:	R30 - R90 [kN]	0,59	0,85	2,09	1,48	3,12
		R120 [kN]	0,47	0,68	1,67	1,19	2,50
$s_{cr,N,fi}$	Spacing:	R30 - R120 [mm]	4 x $h_{ef}$				
$s_{min,fi}$	Minimum spacing:	R30 - R120 [mm]	35			35	
$c_{cr,N,fi}$	Edge distance:	R30 - R120 [mm]	2 x $h_{ef}$				
$c_{min,fi}$	Minimum edge distance:	R30 - R120 [mm]	$c_{min} = 2 \times h_{ef}$ ; if fire attack comes from more than one side, the edge distance of the anchor has to be $\geq 300$ mm				
<b>Fire resistance to concrete pry-out failure</b>							
$k_8$	Pry-out factor:	R30 - R120 [mm]	2,05	1,44	1,15	1,80	1,27

<sup>1)</sup> As a rule, splitting failure can be neglected since cracked concrete and reinforcement is assumed.  
In absence of other national regulations the partial safety factor for resistance under fire exposure  $\gamma_{m,fi} = 1,0$  is recommended

<b>THE screw anchor</b>	<b>Annex C20</b>
<b>Performances</b>	
Essential characteristics under fire exposure	



<b>Table C20: Essential characteristics under fire exposure, stainless steel head styles E, K and J</b>											
Essential characteristics under fire exposure, stainless steel head styles E, K and J			Performances								
			6			8		10		12	
$h_{nom}$	Nominal embedment depth:	[mm]	35	40	55	50	65	55	85	75	105
<b>Fire resistance to steel failure</b>											
$N_{Rk,s,fi}$	Characteristic tension resistance:	R30 [kN]	1,48			2,62		4,21		7,61	
		R60 [kN]	1,12			1,97		3,16		5,24	
		R90 [kN]	0,76			1,33		2,10		3,46	
		R120 [kN]	0,58			1,00		1,58		2,57	
$V_{Rk,s,fi}$	Characteristic shear resistance:	R30 [kN]	1,48			2,62		4,21		7,61	
		R60 [kN]	1,12			1,97		3,16		5,24	
		R90 [kN]	0,76			1,33		2,10		3,46	
		R120 [kN]	0,58			1,00		1,58		2,57	
$M^0_{Rk,s,fi}$	Characteristic bending resistance:	R30 [Nm]	1,27			2,94		5,90		11,96	
		R60 [Nm]	0,97			2,22		4,42		8,93	
		R90 [Nm]	0,66			1,49		2,94		5,90	
		R120 [Nm]	0,50			1,13		2,21		4,38	
<b>Fire resistance to pull-out failure</b>											
$N_{Rk,p,fi}$	Characteristic resistance:	R30-R90 [kN]	0,25	0,63	1,88	1,25	3,09	2,30	4,72	3,50	6,57
		R120 [kN]	0,20	0,50	1,50	1,00	2,47	1,84	3,78	2,80	5,25
<b>Fire resistance to concrete cone failure <sup>1)</sup></b>											
$N_{Rk,c,fi}$	Characteristic resistance:	R30-R90 [kN]	0,59	0,85	2,09	1,48	3,12	1,91	6,33	4,41	10,97
		R120 [kN]	0,47	0,68	1,67	1,19	2,50	1,53	5,06	3,53	8,78
$s_{cr,N,fi}$	Spacing:	R30 - R120 [mm]	4 x $h_{ef}$								
$s_{min,fi}$	Minimum spacing:	R30 - R120 [mm]	35			35		50		75	
$c_{cr,N,fi}$	Edge distance:	R30 - R120 [mm]	2 x $h_{ef}$								
$c_{min,fi}$	Minimum edge distance:	R30 - R120 [mm]	$c_{min} = 2 \times h_{ef}$ ; if fire attack comes from more than one side, the edge distance of the anchor has to be $\geq 300$ mm								
<b>Fire resistance to concrete pry-out failure</b>											
$k_8$	Pry-out factor:	R30 - R120 [mm]	1,87	1,66	1,05	1,71	1,39	1,83	2,00	2,19	2,00
<sup>1)</sup> As a rule, splitting failure can be neglected since cracked concrete and reinforcement is assumed. In absence of other national regulations the partial safety factor for resistance under fire exposure $\gamma_{m,fi} = 1,0$ is recommended											
<b>TXE screw anchor</b>										<b>Annex C21</b>	
<b>Performances</b>											
Essential characteristics under fire exposure											



<b>Table C21: Essential characteristics under fire exposure, stainless steel head styles N, A, W and S</b>												
Essential characteristics under fire exposure, stainless steel head styles A, N, W and S			Performances									
			6			8			10		12	
$h_{nom}$	Nominal embedment depth:	[mm]	35	40	55	50	65	55	85	75	105	
<b>Fire resistance to steel failure</b>												
$N_{Rk,s,fi}$	Characteristic tension resistance:	R30 [kN]	0,24			0,79			1,64		2,95	
		R60 [kN]	0,22			0,63			1,31		2,45	
		R90 [kN]	0,17			0,48			1,05		1,96	
		R120 [kN]	0,12			0,40			0,92		1,57	
$V_{Rk,s,fi}$	Characteristic shear resistance:	R30 [kN]	0,24			0,79			1,64		2,95	
		R60 [kN]	0,22			0,63			1,31		2,45	
		R90 [kN]	0,17			0,48			1,05		1,96	
		R120 [kN]	0,12			0,40			0,92		1,57	
$M^0_{Rk,s,fi}$	Characteristic bending resistance:	R30 [Nm]	0,20			0,84			2,24		4,94	
		R60 [Nm]	0,18			0,67			1,79		4,12	
		R90 [Nm]	0,14			0,51			1,43		3,29	
		R120 [Nm]	0,10			0,42			1,26		2,63	
<b>Fire resistance to pull-out failure</b>												
$N_{Rk,p,fi}$	Characteristic resistance:	R30-R90 [kN]	0,25	0,63	1,88	1,25	3,09	2,30	4,72	3,50	6,57	
		R120 [kN]	0,20	0,50	1,50	1,00	2,47	1,84	3,78	2,80	5,25	
<b>Fire resistance to concrete cone failure <sup>1)</sup></b>												
$N_{Rk,c,fi}$	Characteristic resistance:	R30-R90 [kN]	0,59	0,85	2,09	1,48	3,12	1,91	6,33	4,41	10,97	
		R120 [kN]	0,47	0,68	1,67	1,19	2,50	1,53	5,06	3,53	8,78	
$s_{cr,N,fi}$	Spacing:	R30 - R120 [mm]	4 x $h_{ef}$									
$s_{min,fi}$	Minimum spacing:	R30 - R120 [mm]	35			35			50		75	
$c_{cr,N,fi}$	Edge distance:	R30 - R120 [mm]	2 x $h_{ef}$									
$c_{min,fi}$	Minimum edge distance:	R30 - R120 [mm]	$c_{min} = 2 \times h_{ef}$ , if fire attack comes from more than one side, the edge distance of the anchor has to be $\geq 300$ mm									
<b>Fire resistance to concrete pry-out failure</b>												
$k_8$	Pry-out factor:	R30 - R120 [mm]	1,87	1,66	1,05	1,71	1,39	1,83	2,00	2,19	2,00	
<sup>1)</sup> As a rule, splitting failure can be neglected since cracked concrete and reinforcement is assumed. In absence of other national regulations the partial safety factor for resistance under fire exposure $\gamma_{m,fi} = 1,0$ is recommended												
<b>TXE screw anchor</b>										<b>Annex C22</b>		
<b>Performances</b>												
Essential characteristics under fire exposure												



**Table C22: Essential characteristics under fire exposure, stainless steel head style P**

Essential characteristics under fire exposure, stainless steel head style P			Performances				
			6			8	
$h_{nom}$	Nominal embedment depth:	[mm]	35	40	55	50	65
<b>Fire resistance to steel failure</b>							
$N_{Rk,s,fi}$	Characteristic tension resistance:	R30 [kN]	0,87			2,76	
		R60 [kN]	0,59			2,06	
		R90 [kN]	0,30			1,35	
		R120 [kN]	0,16			1,00	
$V_{Rk,s,fi}$	Characteristic shear resistance:	R30 [kN]	0,87			2,76	
		R60 [kN]	0,59			2,06	
		R90 [kN]	0,30			1,35	
		R120 [kN]	0,16			1,00	
$M^0_{Rk,s,fi}$	Characteristic bending resistance:	R30 [Nm]	0,75			3,11	
		R60 [Nm]	0,51			2,31	
		R90 [Nm]	0,26			1,52	
		R120 [Nm]	0,14			1,12	
<b>Fire resistance to pull-out failure</b>							
$N_{Rk,p,fi}$	Characteristic resistance:	R30 - R90 [kN]	0,25	0,63	1,88	1,25	3,09
		R120 [kN]	0,20	0,50	1,50	1,00	2,47
<b>Fire resistance to concrete cone failure <sup>1)</sup></b>							
$N_{Rk,c,fi}$	Characteristic resistance:	R30 - R90 [kN]	0,59	0,85	2,09	1,48	3,12
		R120 [kN]	0,47	0,68	1,67	1,19	2,50
$s_{cr,N,fi}$	Spacing:	R30 - R120 [mm]	4 x $h_{ef}$				
$s_{min,fi}$	Minimum spacing:	R30 - R120 [mm]	35			35	
$c_{cr,N,fi}$	Edge distance:	R30 - R120 [mm]	2 x $h_{ef}$				
$c_{min,fi}$	Minimum edge distance:	R30 - R120 [mm]	$c_{min} = 2 \times h_{ef}$ , if fire attack comes from more than one side, the edge distance of the anchor has to be $\geq 300$ mm				
<b>Fire resistance to concrete pry-out failure</b>							
$k_8$	Pry-out factor:	R30 - R120 [mm]	1,87	1,66	1,05	1,71	1,39

<sup>1)</sup> As a rule, splitting failure can be neglected since cracked concrete and reinforcement is assumed.

In absence of other national regulations the partial safety factor for resistance under fire exposure  $\gamma_{m,fi} = 1,0$  is recommended

TXE screw anchor	<b>Annex C23</b>
Performances	
Essential characteristics under fire exposure	



**Table C23: Essential characteristics under fire exposure, stainless steel head style T**

Essential characteristics under fire exposure, stainless steel head style T			Performances		
			6		
$h_{nom}$	Nominal embedment depth:	[mm]	35	40	55
<b>Fire resistance to steel failure</b>					
$N_{Rk,s,fi}$	Characteristic tension resistance:	R30 [kN]	1,62		
		R60 [kN]	1,14		
		R90 [kN]	0,67		
		R120 [kN]	0,43		
$V_{Rk,s,fi}$	Characteristic shear resistance:	R30 [kN]	1,62		
		R60 [kN]	1,14		
		R90 [kN]	0,67		
		R120 [kN]	0,43		
$M^0_{Rk,s,fi}$	Characteristic bending resistance:	R30 [Nm]	1,40		
		R60 [Nm]	0,99		
		R90 [Nm]	0,58		
		R120 [Nm]	0,37		
<b>Fire resistance to pull-out failure</b>					
$N_{Rk,p,fi}$	Characteristic resistance:	R30 - R90 [kN]	0,25	0,63	1,88
		R120 [kN]	0,20	0,50	1,50
<b>Fire resistance to concrete cone failure <sup>1)</sup></b>					
$N_{Rk,c,fi}$	Characteristic resistance:	R30 - R90 [kN]	0,59	0,85	2,09
		R120 [kN]	0,47	0,68	1,67
$S_{cr,N,fi}$	Spacing:	R30 - R120 [mm]	4 x $h_{ef}$		
$S_{min,fi}$	Minimum spacing:	R30 - R120 [mm]	35		
$C_{cr,N,fi}$	Edge distance:	R30 - R120 [mm]	2 x $h_{ef}$		
$C_{min,fi}$	Minimum edge distance:	R30 - R120 [mm]	$C_{min} = 2 \times h_{ef}$ , if fire attack comes from more than one side, the edge distance of the anchor has to be $\geq 300$ mm		
<b>Fire resistance to concrete pry-out failure</b>					
$k_8$	Pry-out factor:	R30 - R120 [mm]	1,87	1,66	1,05

<sup>1)</sup> As a rule, splitting failure can be neglected since cracked concrete and reinforcement is assumed.

In absence of other national regulations the partial safety factor for resistance under fire exposure  $\gamma_{m,fi} = 1,0$  is recommended

<b>TXE screw anchor</b>	<b>Annex C24</b>
<b>Performances</b>	
Essential characteristics under fire exposure	



**Table C24: Essential characteristics under fire exposure, stainless steel head style M**

Essential characteristics under fire exposure, stainless steel head style M				Performances				
				6			8	
$h_{nom}$	Nominal embedment depth:	[mm]	35	40	55	50	65	
<b>Fire resistance to steel failure</b>								
$N_{Rk,s,fi}$	Characteristic tension resistance:	R30 [kN]	0,87			0,87		
		R60 [kN]	0,72			0,72		
		R90 [kN]	0,58			0,58		
		R120 [kN]	0,51			0,51		
$V_{Rk,s,fi}$	Characteristic shear resistance:	R30 [kN]	0,87			0,87		
		R60 [kN]	0,72			0,72		
		R90 [kN]	0,58			0,58		
		R120 [kN]	0,51			0,51		
$M^0_{Rk,s,fi}$	Characteristic bending resistance:	R30 [Nm]	0,75			0,75		
		R60 [Nm]	0,62			0,62		
		R90 [Nm]	0,50			0,50		
		R120 [Nm]	0,44			0,44		
<b>Fire resistance to pull-out failure</b>								
$N_{Rk,p,fi}$	Characteristic resistance:	R30-R90 [kN]	0,25	0,63	1,88	1,25	3,09	
		R120 [kN]	0,20	0,50	1,50	1,00	2,47	
<b>Fire resistance to concrete cone failure <sup>1)</sup></b>								
$N_{Rk,c,fi}$	Characteristic resistance:	R30-R90 [kN]	0,59	0,85	2,09	1,48	3,12	
		R120 [kN]	0,47	0,68	1,67	1,19	2,50	
$s_{cr,N,fi}$	Spacing:	R30 - R120 [mm]	4 x $h_{ef}$					
$s_{min,fi}$	Minimum spacing:	R30 - R120 [mm]	35		35			
$c_{cr,N,fi}$	Edge distance:	R30 - R120 [mm]	2 x $h_{ef}$					
$c_{min,fi}$	Minimum edge distance:	R30 - R120 [mm]	$c_{min} = 2 \times h_{ef}$ ; if fire attack comes from more than one side, the edge distance of the anchor has to be $\geq 300$ mm					
<b>Fire resistance to concrete pry-out failure</b>								
$k_8$	Pry-out factor:	R30 - R120 [mm]	1,87	1,66	1,05	1,71	1,39	

<sup>1)</sup> As a rule, splitting failure can be neglected since cracked concrete and reinforcement is assumed.  
In absence of other national regulations the partial safety factor for resistance under fire exposure  $\gamma_{m,fi}$  = 1,0 is recommended

<b>TXE screw anchor</b>	<b>Annex C25</b>
<b>Performances</b>	
Essential characteristics under fire exposure	



**Table C25: Essential characteristics under fire exposure, stainless steel head style F**

Essential characteristics under fire exposure, stainless steel head style F			Performances				
			6			8	
	Inner thread	[-]	M8/M10	M10	M8/M10	M10; M12	
$h_{nom}$	Nominal embedment depth:	[mm]	35	40	55	50	65
<b>Fire resistance to steel failure</b>							
$N_{Rk,s,fi}$	Characteristic tension resistance:	R30 [kN]	0,66	1,01	0,66	1,44	
		R60 [kN]	0,56	0,83	0,56	1,07	
		R90 [kN]	0,46	0,65	0,46	0,70	
		R120 [kN]	0,41	0,57	0,41	0,51	
$V_{Rk,s,fi}$	Characteristic shear resistance:	R30 [kN]	0,66	1,01	0,66	1,44	
		R60 [kN]	0,56	0,83	0,56	1,07	
		R90 [kN]	0,46	0,65	0,46	0,70	
		R120 [kN]	0,41	0,57	0,41	0,51	
$M^0_{Rk,s,fi}$	Characteristic bending resistance:	R30 [Nm]	0,57	0,87	0,57	1,62	
		R60 [Nm]	0,48	0,72	0,48	1,20	
		R90 [Nm]	0,40	0,56	0,40	0,78	
		R120 [Nm]	0,35	0,49	0,35	0,57	
<b>Fire resistance to pull-out failure</b>							
$N_{Rk,c,fi}$	Characteristic resistance:	R30 - R90 [kN]	0,25	0,63	1,88	1,25	3,09
		R120 [kN]	0,20	0,50	1,50	1,00	2,47
<b>Fire resistance to concrete cone failure <sup>1)</sup></b>							
$N_{Rk,c,fi}$	Characteristic resistance:	R30 - R90 [kN]	0,59	0,85	2,09	1,48	3,12
		R120 [kN]	0,47	0,68	1,67	1,19	2,50
$s_{cr,N,fi}$	Spacing:	R30 - R120 [mm]	4 x $h_{ef}$				
$s_{min,fi}$	Minimum spacing:	R30 - R120 [mm]	35			35	
$c_{cr,N,fi}$	Edge distance:	R30 - R120 [mm]	2 x $h_{ef}$				
$c_{min,fi}$	Minimum edge distance:	R30 - R120 [mm]	$c_{min} = 2 \times h_{ef}$ ; if fire attack comes from more than one side, the edge distance of the anchor has to be $\geq 300$ mm				
<b>Fire resistance to concrete pry-out failure</b>							
$k_8$	Pry-out factor:	R30 - R120 [mm]	1,87	1,66	1,05	1,71	1,39

<sup>1)</sup> As a rule, splitting failure can be neglected since cracked concrete and reinforcement is assumed.  
In absence of other national regulations the partial safety factor for resistance under fire exposure  $\gamma_{m,fi} = 1,0$  is recommended

<b>TXE screw anchor</b>	<b>Annex C26</b>
<b>Performances</b>	
Essential characteristics under fire exposure	

