

DeVorm

Mute PET Felt Acoustic Panels

Installation guide

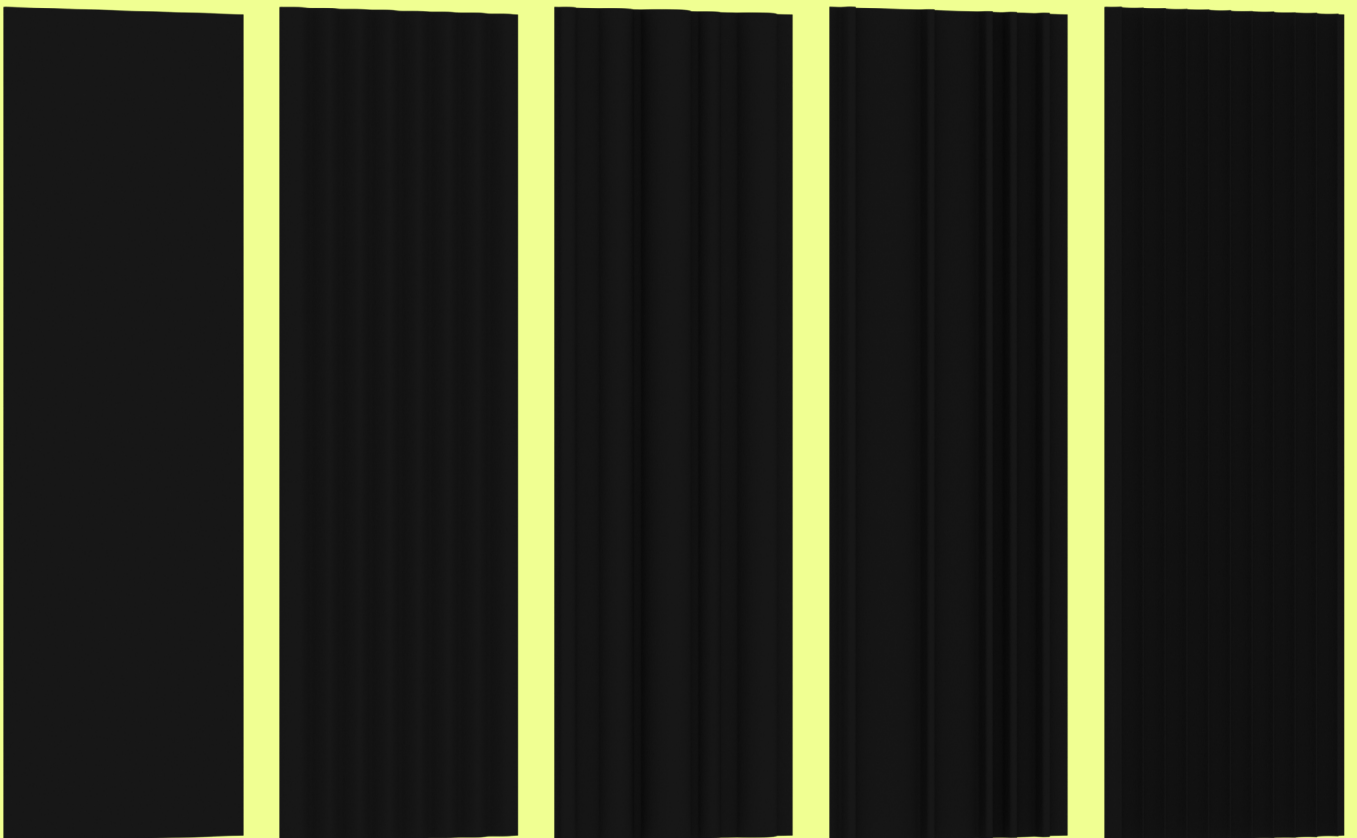

Tools required

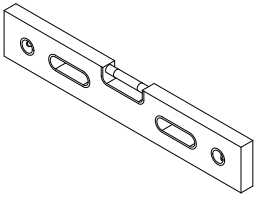
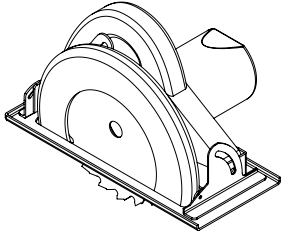
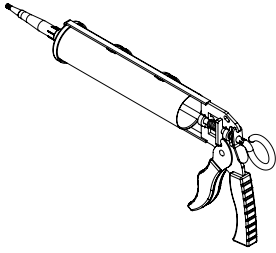
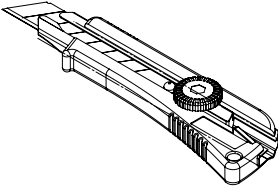
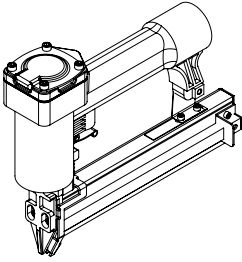
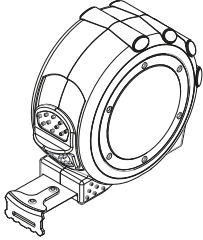
Level	Circular saw	Caulking gun
		
Snap-off blade cutter	Nail gun	Measuring tape
		

Panels

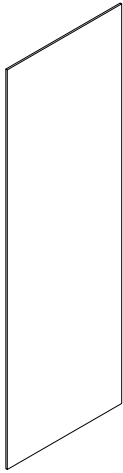
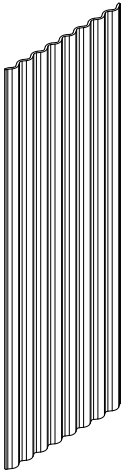
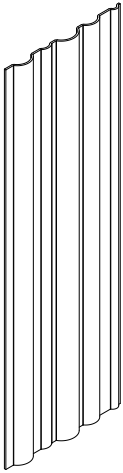
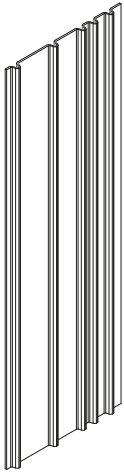
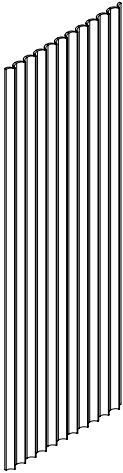
Mute Flat	Mute Flow	Mute Fit	Mute Fraction	Mute Peak
				

Before you begin

- ❗ Since PET Felt panels are made of recycled material, they may have slight colour differences.

To keep the colour differences to a minimum, we advise installing the panels in the same order as stacked in a box, keeping the top of the panel as the front side.

PET Felt panels should be handled carefully during transportation and unloading. The dimensions and flexibility of a single panel usually require two people to lift it.

If you install the Mute panels with a fire retardant treatment, make sure to mount them on a non-combustible background and / or use non-combustible mounting materials.

To achieve the most seamless transition between the panels, it is important to place them tightly against each other. You can do this by firmly pressing a loose panel against the already installed part before attaching it.

Installation order

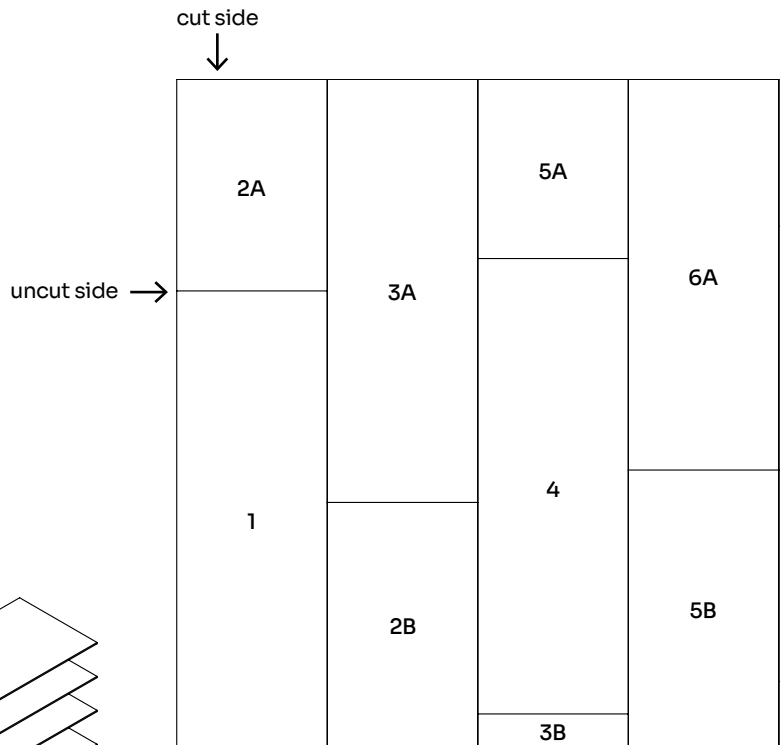

If you need to stack the panels, we advise you to use the pattern as shown here. An asymmetric pattern ensures that the colour differences are less visible. Always place the cutting side on the outside (ceiling or floor side).

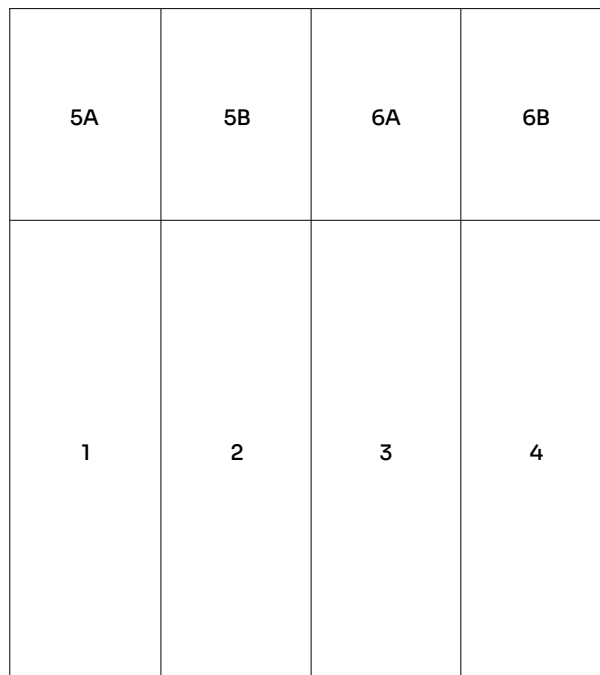
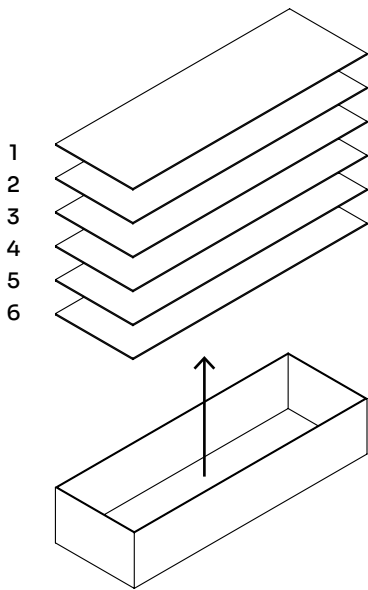

Never use one panel to fill the missing smaller pieces. We advise cutting / installing the panels in the same order as stacked in a box to avoid colour differences.

Cutting panels to size

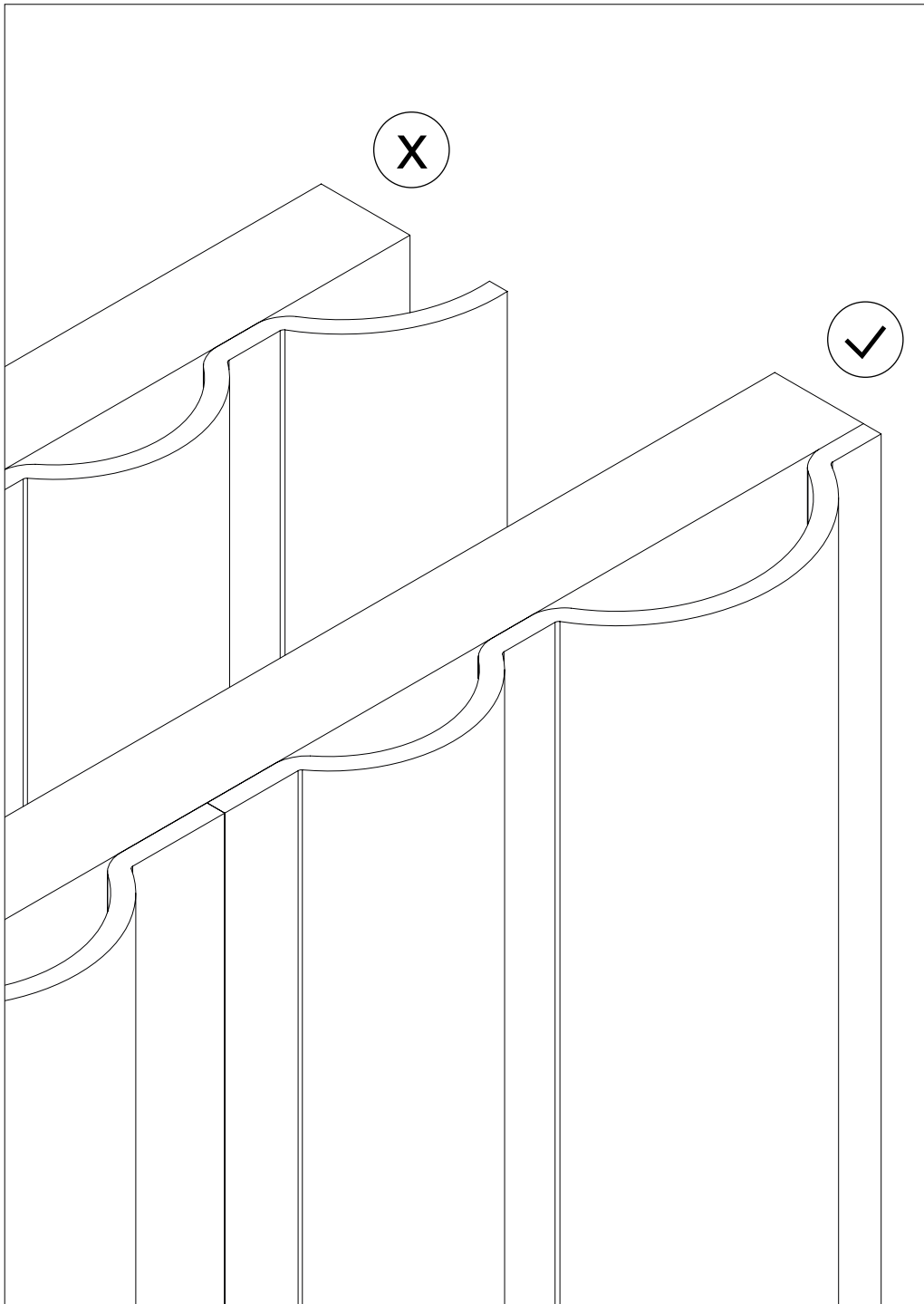

PET Felt panels can be cut using a circular saw or a blade cutter.

Circular saw

The best way to cut PET Felt panels is using a circular saw. We recommend testing the speed of the saw first to prevent the material from melting. If the cut sides of the panels get too rough, you can gently smoothen them with sanding paper.

Blade cutter

Smaller, tailor-made cut-outs and alterations can be made on-site with a snap-off blade cutter and a ruler.

Define how you would like to cut the panels. If a panel has flat areas in its pattern (such as Mute Fit or Mute Fraction*), make sure that every part you cut ends with a flat edge.

You can draw the reference markings for the cutting lines on the backside of the panel.

*See Appendix for the measurements of Mute Fit and Mute Fraction.

Installation using an adhesive

1 Prepare the surface

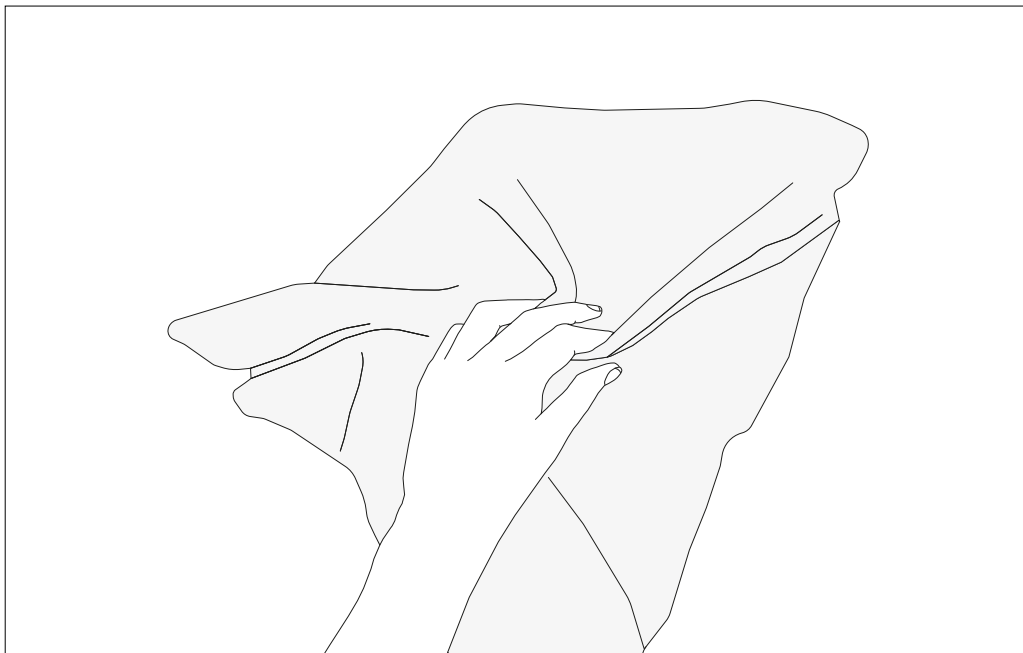

Make sure the surface is flat and clean.

2 Apply the adhesive

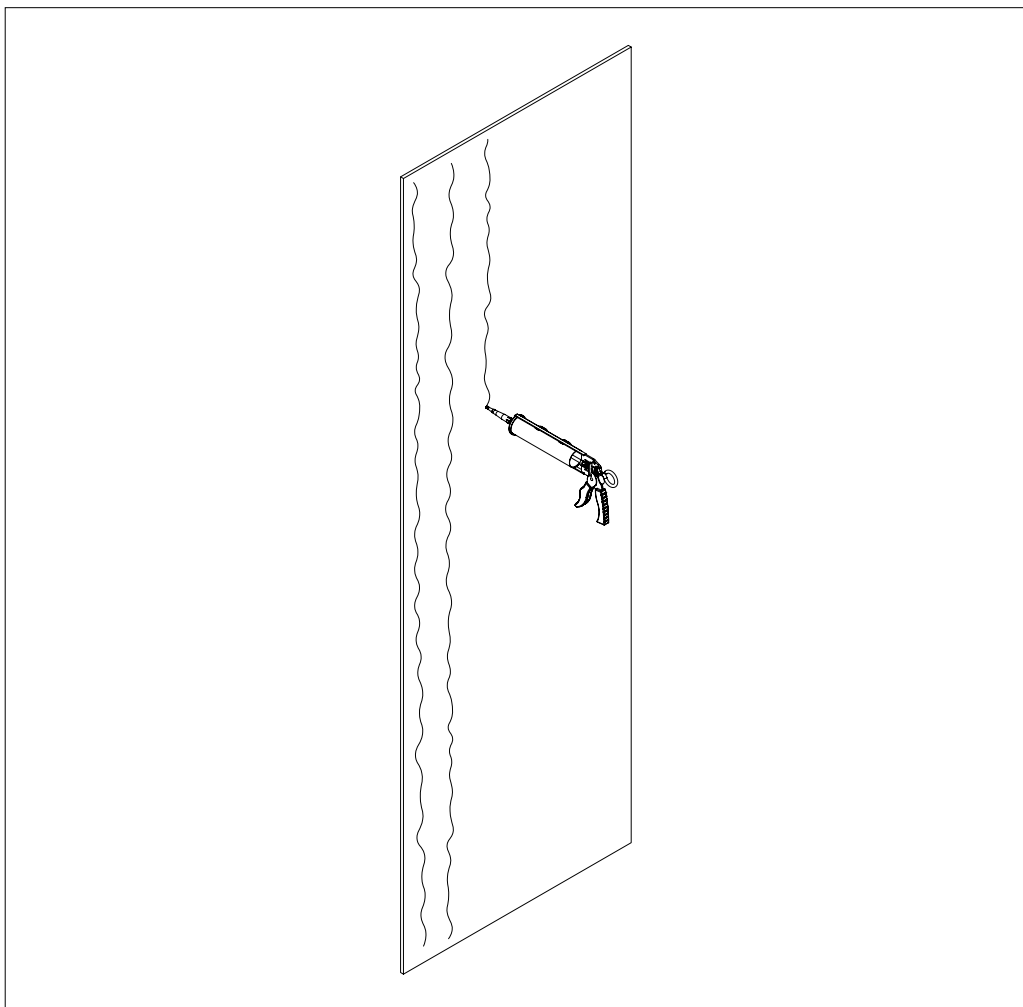

Apply the adhesive on the backside of the panel following the manufacturer's instructions.

3 Mount the panels

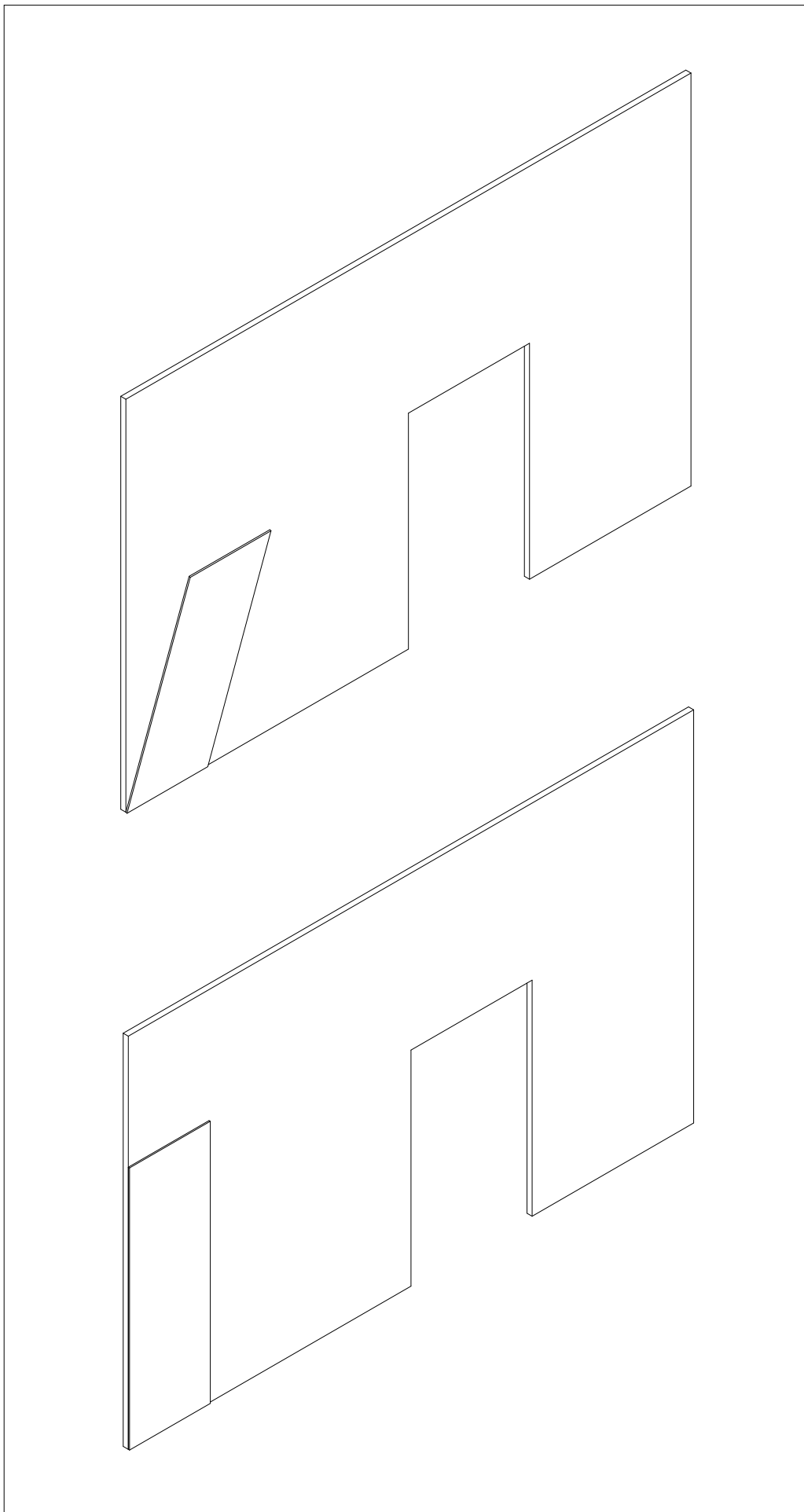

Place the panel against the surface, starting at the bottom. Make sure it is properly aligned using a level.

Press the panel firmly against the surface, making sure that corners and edges are properly attached. *

Repeat these steps until the installation is complete.

* Mute Peak is a bendable panel that can be applied on both flat and curved surfaces. To ensure the panel is properly attached to the surface, press onto the panel until the adhesive has fully dried out. If the surface allows for it, use a nail gun to fasten the edges of the panel.

4 Allow the adhesive to cure

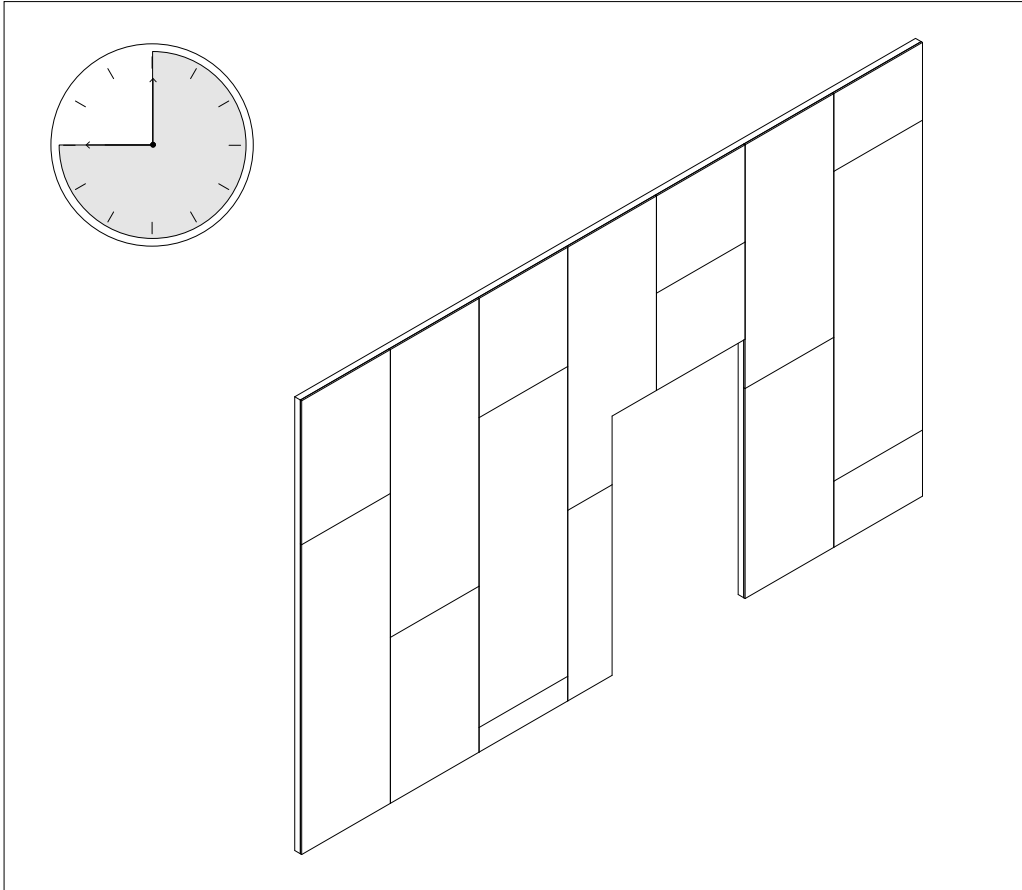

The curing time may vary, follow the adhesive manufacturer's instructions.

Installation using a nail gun

1 Prepare wooden framework

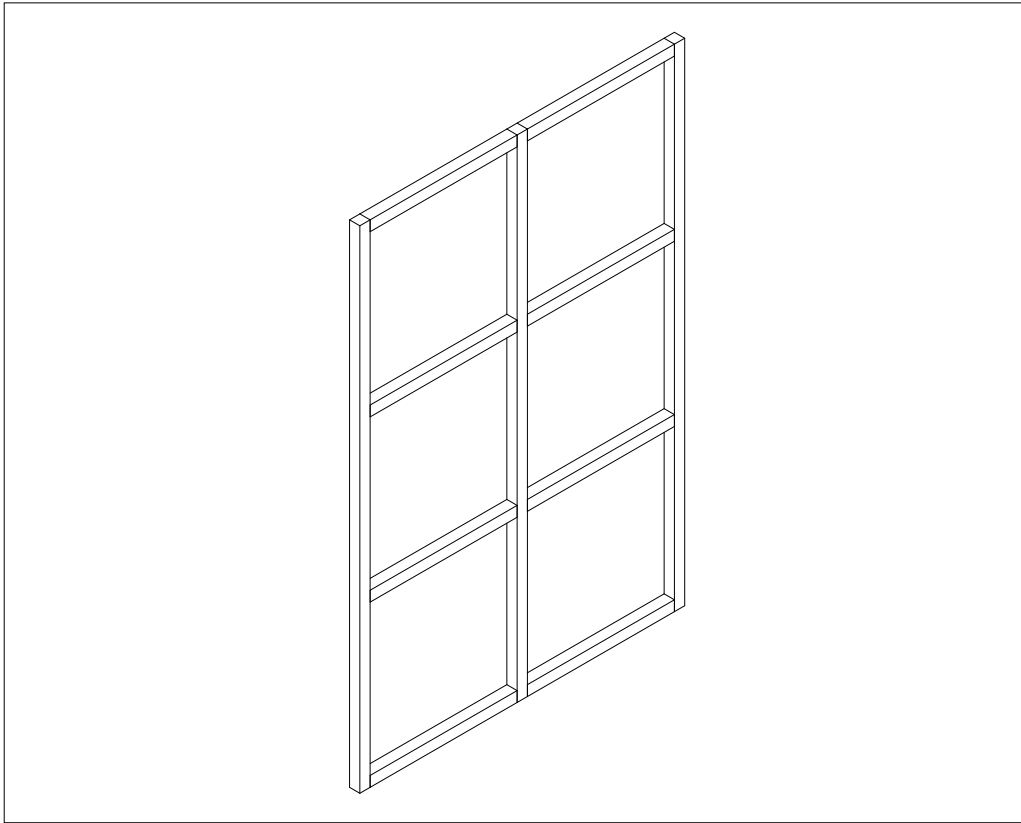

A wooden framework is necessary if you install the panels using a nail gun.

Make sure the frame is levelled. You can use a level to check that.

2 Install the panels

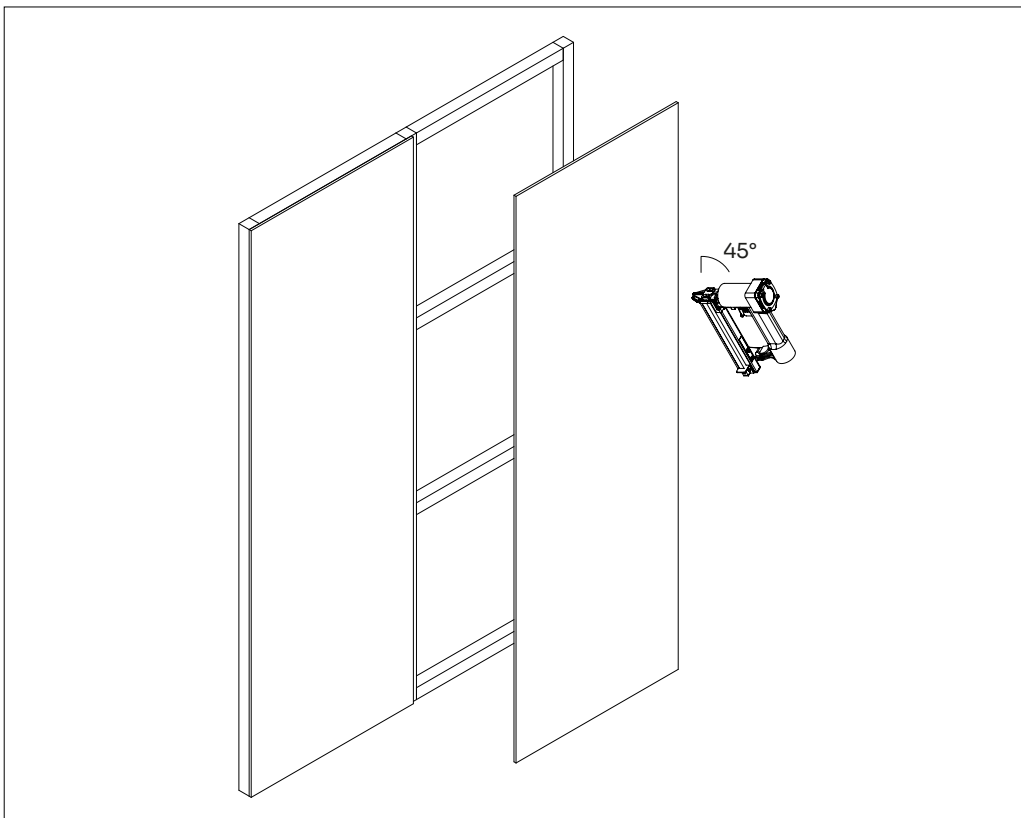

Test the pressure of the nail gun and adjust it, so that the nails don't go too deep into the material.

For a better grip of the headless nail, the nails should be applied at an angle of approximately 45°.

Appendix

Mute Fit

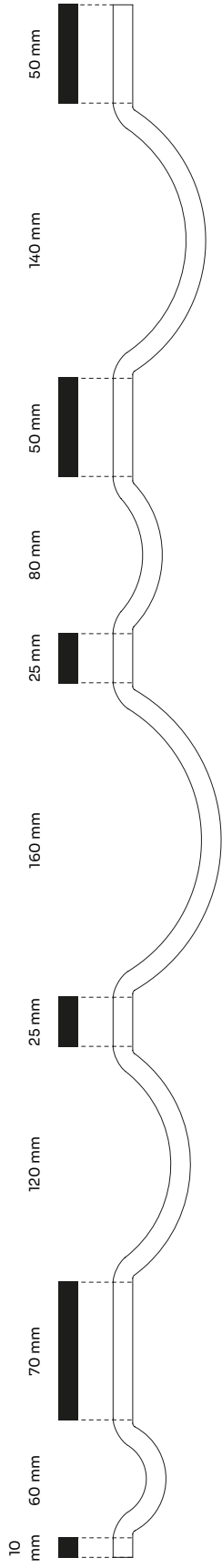

Mute Fraction

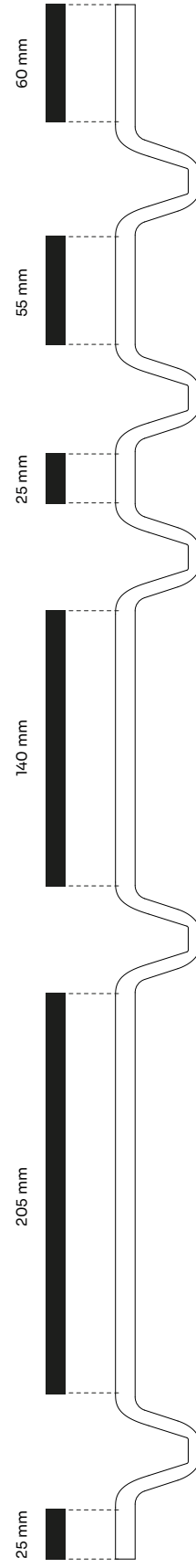

DeVorm



Yhteystiedot
Pyymosantie 5 a
01720 Vantaa
Suomi

Ota yhteyttä
T 045 3238 238
E myynti@jvtuonti.fi
W www.jvtuonti.fi