

# Vibro-AM

## ANTIVIBRATION SPRING MOUNTS

### APPLICATIONS

Antivibration spring mounts **Vibro-AM** are used for low frequency vibration control (low speed rotation 400 RPM upwards) such as air compressors, two-cycle engines, water coolers, air handling units etc.

### DESCRIPTION

At their base, the antivibration spring mounts **Vibro-AM** have a galvanized metal plate with adequate thickness covered by a special rubber pad, resistant to outdoor conditions. The advanced design of the rubber profile offers better isolation efficiency at high frequencies, that can be transmitted through its metal structure. The oval base has two holes for fixing with M8 pass-through bolts. At the upper part there is a M8 bolt for fixing at the machinery. The spring complies with ISO EN 10270 requirements.

### SELECTION TABEL

TYPE	LOAD RANGE (Kp)
Vibro-AM.25	8 - 25
Vibro-AM.50	20 - 50
Vibro-AM.100	40 - 100
Vibro-AM.150	80 - 150

(1 kp=10N)

### DYNAMIC CHARACTERISTICS

**Deflection** (at maximum load): **25 mm**

**Natural Frequency** (at maximum load): **3 Hz**

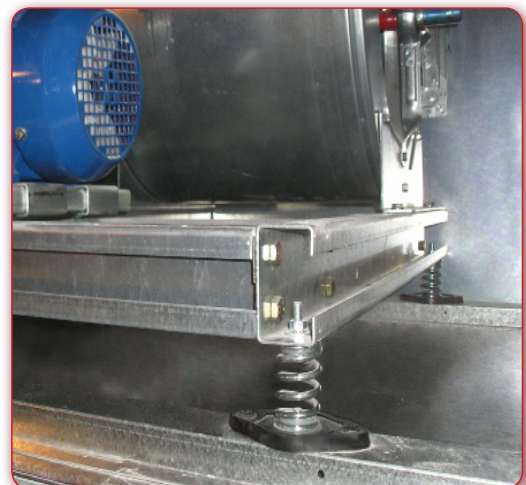
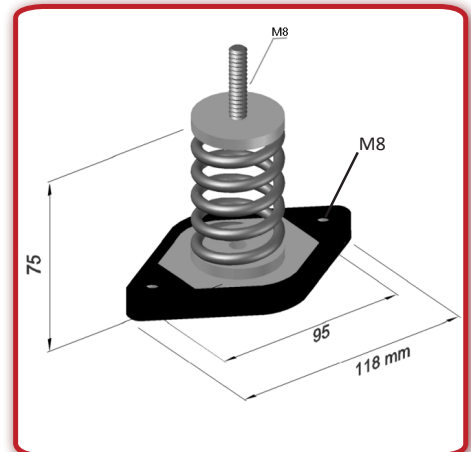

VIBRO AM APPLICATION IN CENTIFUGAL FAN

Design and Production according to International Standard ISO 9001.2000.

**ALPHA ACOUSTIKI LTD**

73 Apostolopoulou St. Chalandri 15231 Greece

T: +30 210 6779875 - F: +30 210 6779269

[www.vibro.gr](http://www.vibro.gr) - [info@vibro.gr](mailto:info@vibro.gr)